

New

Gears

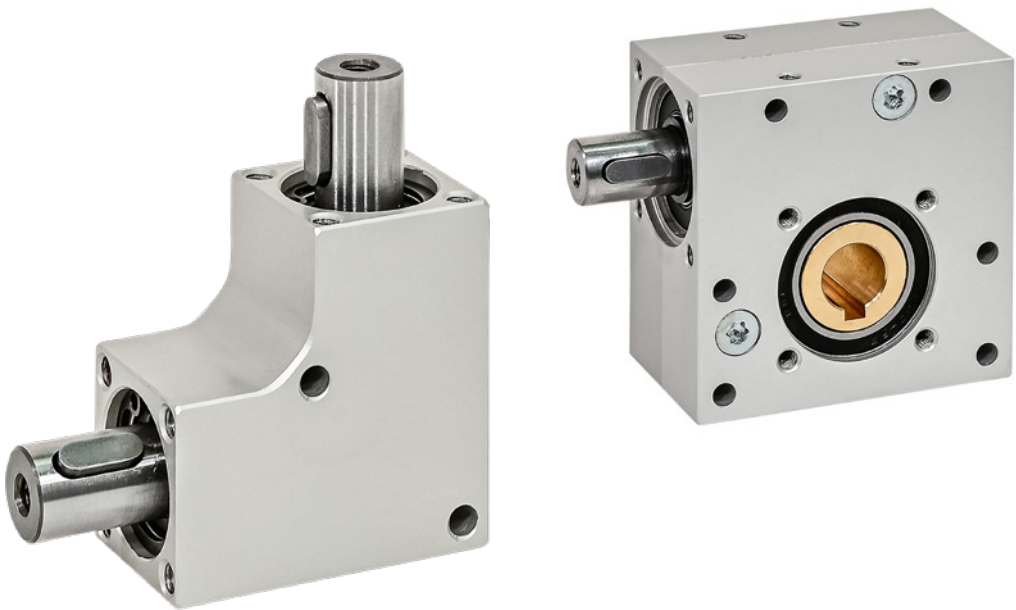

DESIGNED
FOR ENGINEERING

Bevel Gear Boxes

Housing Aluminum

SPECIFICATION

Type

- Type L: Angular gear 90°

Housing

- Aluminum
- Sealed to prevent dust entry
- Anodized, natural color **AN**

Bevel gear wheels

Steel, case-hardened

Ball bearing

- Steel
- Sealed (sealing disks 2RS)

Temperature range: -20 °C to +60 °C



INFORMATION

Bevel gear boxes GN 3971 can transmit high torque despite their very compact dimensions. They can readily be used for a multitude of applications, such as height adjustments or to change the direction of shaft rotation.

The numerous fastening holes allow for simple mounting in any orientation or position. The parallel keys can take any angular positions.

TECHNICAL INFORMATION

- Keyway DIN 6885 (see page A16)
- ISO-Fundamental Tolerances (see page A21)

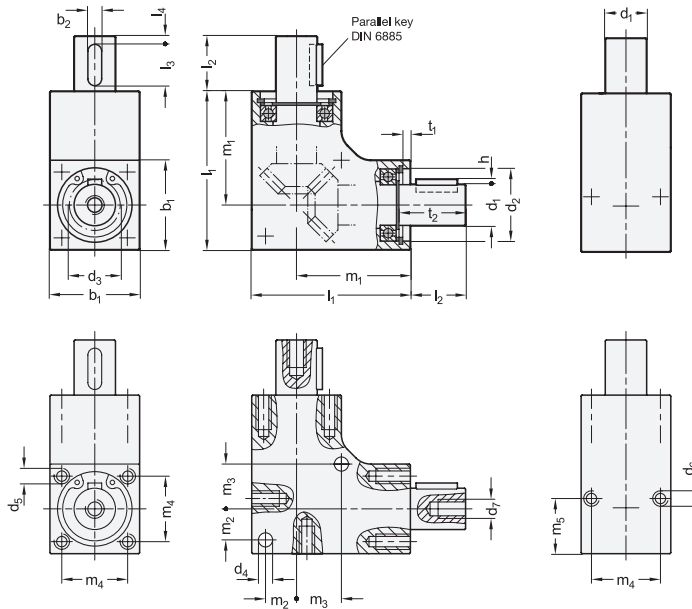

Description	b_1	d_1 j6	b_2	d_2	d_3^{**}	d_4	d_5^{***}	d_6^{***}	d_7^{****}	h	l_1	l_2	l_3	l_4	m_1	m_2	m_3	m_4	m_5	t_1	t_2	
GN 3971-18-L-6-AN	18	6	2	13	-	3.1	M3	M3	M3	0.8	32	12	8	2	23	6	8.5	13	11	2.1	15.4	55
GN 3971-20-L-8-AN	20	8	2	16	9.2	3.1	M3	M3	M3	0.8	35	12	8	2	25	7	10	15	10	1.95	15.3	80
GN 3971-24-L-10-AN	24	10	4*	19	11.8	4.1	M4	M4	M4	1.5	42	16	12	3	30	8	12	18	16	2	18	144
GN 3971-26-L-12-AN	26	12	4	21	13.6	4.1	M4	M4	M4	1.5	46	16	12	3	33	9	13	20	16	2	19.5	190
GN 3971-30-L-12-AN	30	12	4	24	16.4	4.1	M4	M4	M5	1.5	53	16	12	3	38	11	15	22	16	2.1	18.3	270
GN 3971-32-L-12-AN	32	12	4	28	19.8	4.1	M4	M4	M5	1.5	56	16	12	3	40	12	17	24	16	2.1	18.3	332
GN 3971-35-L-12-AN	35	12	4	30	20.4	4.1	M4	M4	M5	1.5	60	16	12	3	42.5	13.5	17.5	26	16	2.1	18.3	418

* Deviating from DIN 6885

** Theoretically usable hub diameter

*** Usable thread depth: min. $2 \times d_5 / d_6$

**** Usable thread depth: min. $1.6 \times d_7$

Mechanical Features

Gear ratio i	1 : 1
Circumferential backlash at the drive shaft	$3^\circ \pm 0.5^\circ$
Shaft direction of rotation	Any
Life expectancy (guideline)	1.000 hours under full load at a rotational speed of 500 rpm, assuming the gear box is operating for 20% of every 5 minutes (1 minute of operation + 4 minutes break) at an ambient temperature of 20 °C
Maintenance	Permanent lubrication with grease, maintenance-free

b1	Max. torque in Nm			Max. radial force in N*	Max. axial force in N**
	at 100 min-1	at 500 min-1	at 1000 min-1		
18	0.35	0.1	0.05	60	60
20	0.75	0.3	0.15	100	100
24	2.5	1	0.5	120	120
26	4	1.5	0.75	140	140
30	5	2	1	240	240
32	8	3	1.5	550	550
35	10	4	2	550	550

* At axial force = 0

** At radial force = 0

Assembly Instructions

Do not exert any forces onto the housing or into the bearings during assembly. Use of the threaded holes d_6 in the shaft is recommended. The use of a corresponding coupling is recommended to compensate for manufacturing-related shaft offsets and runout tolerances as well as for damping vibrations and shocks.

Application example

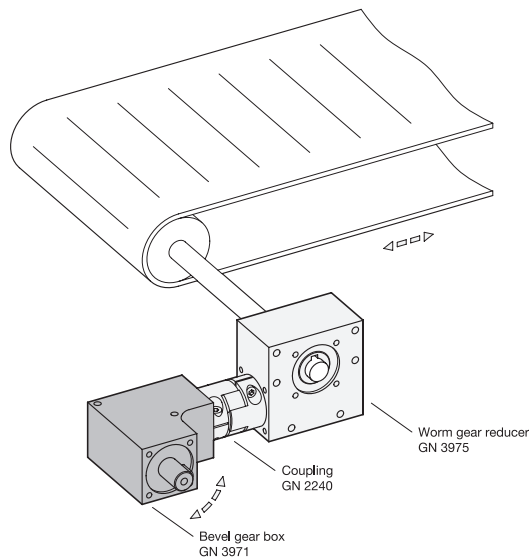

Worm Gear Reducers

Housing Aluminum

SPECIFICATION

Type

- Type **A**: Output on one side

Housing

- Aluminum
- Sealed to prevent dust entry
- Anodized, natural color **AN**

Worm screw, steel

Worm wheel, brass

Ball bearing

- Steel
- Sealed (sealing disks 2RS)

Temperature range: -20 °C to +60 °C



INFORMATION

Worm gear reducers GN 3975 can transmit high torque despite their very compact dimensions. They can readily be used for a multitude of applications, such as incline adjustments or to change the direction of shaft rotation.

The numerous fastening holes allow for simple mounting in any orientation or position. The parallel keys can take any angular positions.

Depending on the gear ratio, there may be no static self-braking between the worm screw and worm wheel, meaning that the worm wheel can be turned out of a resting state by a torque coming from the output end.

TECHNICAL INFORMATION

- Keyway DIN 6885 (see page A16)
- ISO-Fundamental Tolerances (see page A21)

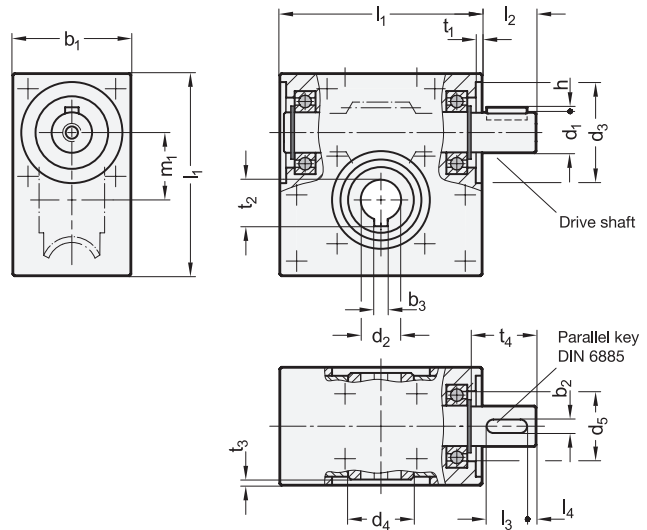

Description	m1	d1 j6	Gear ratio i	b1	b2	b3 JS9	d2 H7	d3	d4	d5	h	l1	l2	l3	l4	t1	t2	t3	t4	Δ _Δ
GN 3975-20-A-12-13-AN	20	12	13	35	4	4	12	30	20	27.4	1.5	60	16	12	3	2	13.8	1.6	18.3	422
GN 3975-20-A-12-15-AN	20	12	15	35	4	4	12	30	20	27.4	1.5	60	16	12	3	2	13.8	1.6	18.3	425
GN 3975-20-A-12-18-AN	20	12	18	35	4	4	12	30	20	27.4	1.5	60	16	12	3	2	13.8	1.6	18.3	426
GN 3975-20-A-12-23-AN	20	12	23	35	4	4	12	30	20	27.4	1.5	60	16	12	3	2	13.8	1.6	18.3	428
GN 3975-20-A-12-30-AN	20	12	30	35	4	4	12	30	20	27.4	1.5	60	16	12	3	2	13.8	1.6	18.3	438
GN 3975-20-A-12-40-AN	20	12	40	35	4	4	12	30	20	27.4	1.5	60	16	12	3	2	13.8	1.6	18.3	426
GN 3975-20-A-12-65-AN	20	12	65	35	4	4	12	30	20	27.4	1.5	60	16	12	3	2	13.8	1.6	18.3	432

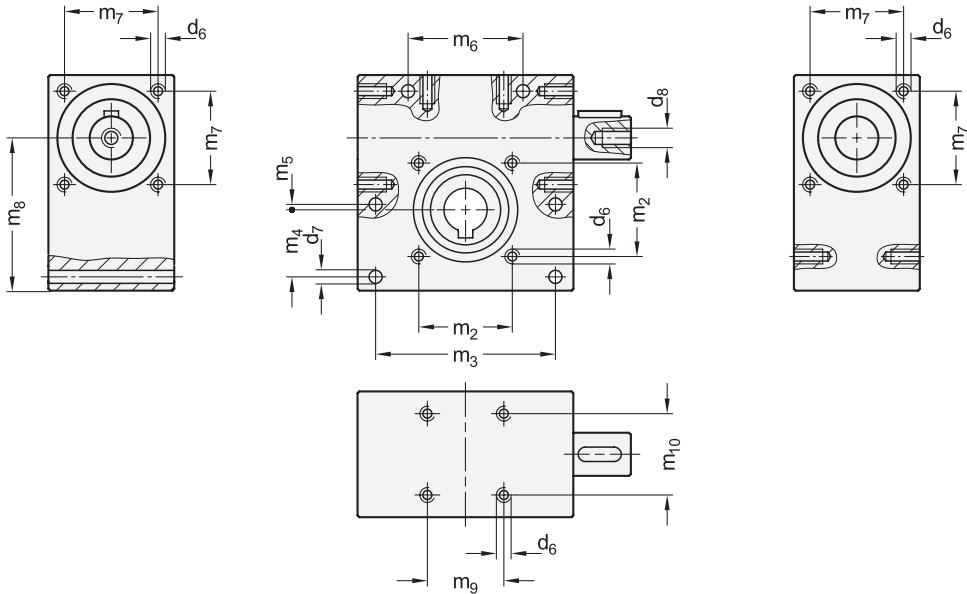

Description	m1	d6*	d7	d8*	m2	m3	m4	m5	m6	m7	m8	m9	m10	Δ
GN 3975-20-A-12-13-AN	20	M 4	4.2	M 5	26	50	17.5	1.5	31	26	42.5	22.5	26	422
GN 3975-20-A-12-15-AN	20	M 4	4.2	M 5	26	50	17.5	1.5	31	26	42.5	22.5	26	425
GN 3975-20-A-12-18-AN	20	M 4	4.2	M 5	26	50	17.5	1.5	31	26	42.5	22.5	26	426
GN 3975-20-A-12-23-AN	20	M 4	4.2	M 5	26	50	17.5	1.5	31	26	42.5	22.5	26	428
GN 3975-20-A-12-30-AN	20	M 4	4.2	M 5	26	50	17.5	1.5	31	26	42.5	22.5	26	438
GN 3975-20-A-12-40-AN	20	M 4	4.2	M 5	26	50	17.5	1.5	31	26	42.5	22.5	26	426
GN 3975-20-A-12-65-AN	20	M 4	4.2	M 5	26	50	17.5	1.5	31	26	42.5	22.5	26	432

* Usable thread depth: min. $1.6 \times d_6 / d_8$

Mechanical Features

Circumferential backlash at the drive shaft	$1^\circ \pm 0.5^\circ$
Shaft direction of rotation	Any
Worm wheel set design	Left-hand
Life expectancy (guideline)	1.000 hours under full load at a rotational speed of 500 rpm, assuming the gear box is operating for 20% of every 5 minutes (1 minute of operation + 4 minutes break) at an ambient temperature of 20 °C
Maintenance	Permanent lubrication with grease, maintenance-free

m1	Gear ratio	Max. input torque in Nm*			Max. output torque in Nm*			Input side		Output side		Efficiency in %	Self-braking
		at 100 min ⁻¹	at 500 min ⁻¹	at 1000 min ⁻¹	at 100 min ⁻¹	at 500 min ⁻¹	at 1000 min ⁻¹	Max. radial force in N**	Max. axial force in N***	Max. radial force in N**	Max. axial force in N***		
20	13	2.1	1.8	1.5	15	13	11	200	200	500	500	56	-
20	15	1.5	1.3	1	12	10	8	250	250	500	500	52	-
20	18	1.1	0.9	0.7	11	9	7	250	250	500	500	55	x
20	23	0.9	0.7	0.5	10	8	6	250	250	500	500	50	x
20	30	0.6	0.5	0.4	8.5	7	5.5	350	350	500	500	45	x
20	40	0.35	0.31	0.26	5.5	4.8	4	400	400	500	500	39	x
20	65	0.24	0.2	0.16	4.5	3.8	3	500	500	500	500	29	x

* Input side speed
 ** At axial force = 0
 *** At radial force = 0

Assembly Instructions

Do not exert any forces onto the housing or into the bearings during assembly. Use of the threaded holes d7 in the shaft is recommended. The use of a corresponding coupling is recommended to compensate for manufacturing-related shaft offsets and runout tolerances as well as for damping vibrations and shocks.

Application example

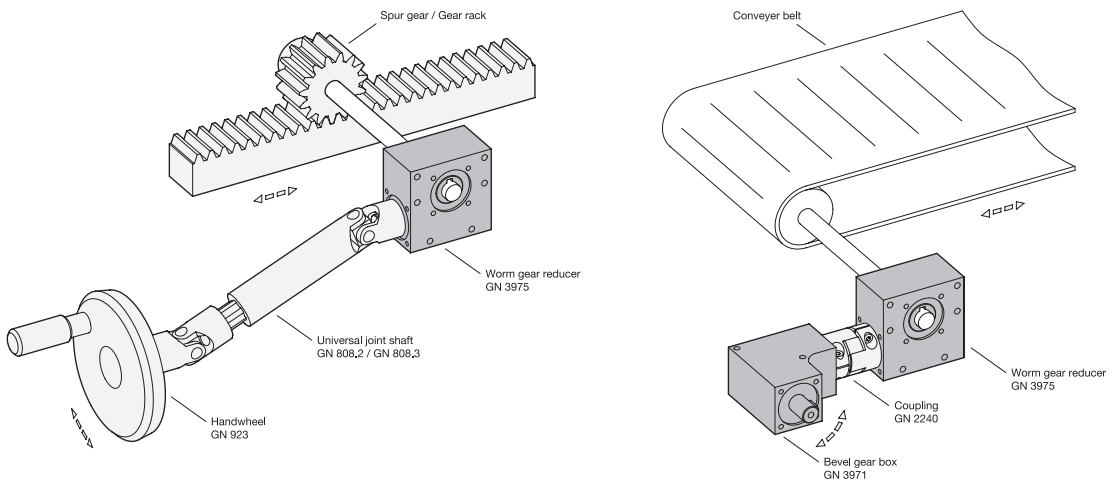

COPYRIGHT © 2022

Elesa S.p.A and OTTO GANTER GmbH & Co. KG

All rights reserved.

No part of this catalogue can be reproduced in whole
or in part without prior written permission from

Elesa S.p.A or OTTO GANTER GmbH & Co. KG



Find out more on [elesa-ganter.com](https://www.elesa-ganter.com)

ELESA S.p.A.
Via Pompei 29
20900 Monza (MB)
Italy
+39 039 28 111
info@elesa.com
[elesa.com](https://www.elesa.com)

OTTO GANTER GmbH & Co.KG
Tribberger Straße 3
78120 Furtwangen
Germany
+49 7723 65 07 0
info@ganternorm.com
[ganternorm.com](https://www.ganternorm.com)



DESIGNED
FOR ENGINEERING