

New

Couplings



DESIGNED
FOR ENGINEERING

Couplings

General notes

INTRODUCTION

Couplings create connections between drive shafts and driven shafts in order to transmit rotary motion and torque. For example, they are used to combine the shafts of motors and transmissions into a single drive unit.

Alongside the primary purpose of transmitting torque, couplings also carry out other important tasks:

- Compensating for shaft offsets and misalignments
- Absorbing runout errors and axial motions
- Damping vibrations and shocks

Couplings are used in a very wide range of applications. The spectrum ranges from simple drives to complex control, regulation and measurement applications.

MISALIGNMENT AND RUNOUT TOLERANCES

Like all mechanical parts, shafts are subjected to manufacturing and assembly tolerances that generally cannot be entirely eliminated even with extensive technical measures.

If these deviations are not taken into account in the design, the result can be vibrations, running noises, and wear or damage to the shafts and their bearings.

Suitable couplings not only are able to effectively compensate for misalignment and runout errors, they also greatly simplify the assembly process, thereby reducing the overall labor required.

Shaft misalignment and runout errors can vary in nature and should always be taken into consideration when selecting the appropriate coupling.

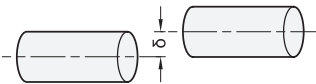
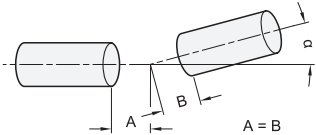
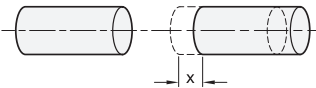
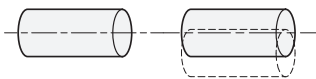
Error type	Misalignment diagram
<p>Lateral</p> <p>The axes of the shafts are in fact parallel, but they are offset laterally and do not line up.</p>	
<p>Angular</p> <p>The axes of the shafts do not lie in the same plane; they meet at a certain angle.</p>	
<p>Axial</p> <p>The shafts move axially along the axis of rotation.</p>	
<p>Runout</p> <p>The shafts move radially out of the center of the axis of rotation.</p>	

Couplings

General notes

AREAS OF APPLICATION - CLASSES - COUPLING TYPES

The applications of couplings can generally be divided into two classes.

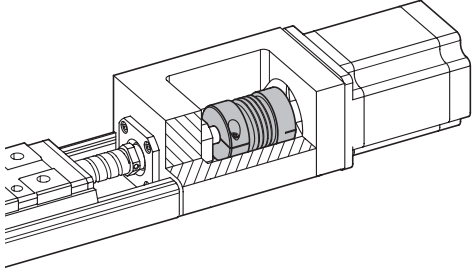
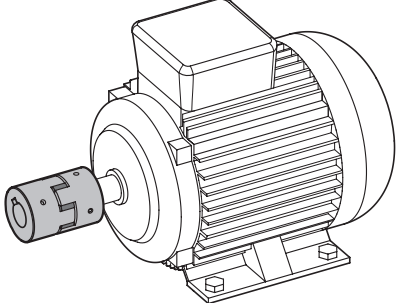



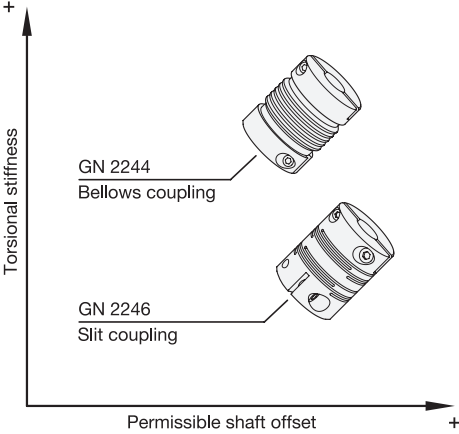
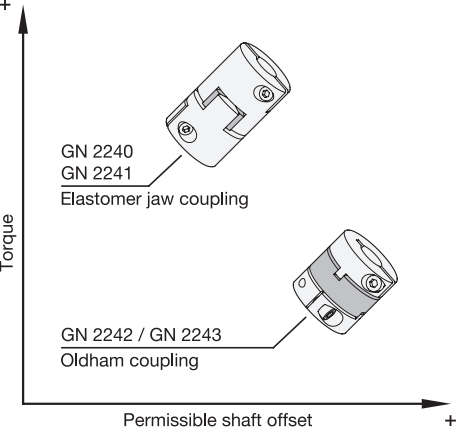



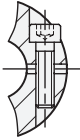

Motion control	Torque and power transmission
<p>For motion control applications, the rotational movement is transmitted with very high precision and accuracy. This requires a coupling type with a high torsional stiffness and zero backlash in the direction of rotation.</p> <p>Typical applications are: Servo or stepper motors for linear axes, industrial robots, test benches, etc.</p> 	<p>For torque and power transmission, the focus lies on pure transmission of force. This requires couplings that can withstand high torques and heavy loads while functioning reliably in harsh conditions.</p> <p>Typical applications are: Conveyor systems, pumps and agitators, packaging machines, etc.</p> 

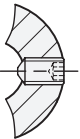
Two coupling types are available for each of the application classes described above.

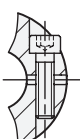
Bellows couplings and beam couplings	Elastomer jaw couplings and oldham couplings
 <p>Bellows couplings offer high torsional stiffness. This makes them excellent for precise and controlled movements.</p> <p>Beam couplings have lower torsional stiffness compared with bellows couplings, but they can compensate for higher shaft misalignments.</p>	 <p>Elastomer jaw couplings are designed for high torque transmission and can be used in all manner of applications.</p> <p>Oldham couplings transmit less torque but can compensate for higher shaft misalignments.</p>

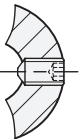

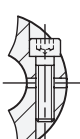

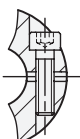

Couplings

Overview of types

Standard	Shaft Ø in mm	Hub clamping	Rated torque in Nm	Misalignment			Zero backlash	
				axial	lateral	angular		
GN 2240 see page 6 Elastomer jaw couplings		3 - 25		0.7 - 60	X	X	X	
GN 2241 see page 10 Elastomer jaw couplings		3 - 25		0.7 - 60	X	X	X	
GN 2242 see page 14 Oldham couplings		4 - 20		1 - 28		X	X	
GN 2243 see page 16 Oldham couplings		2 - 20		0.5 - 28		X	X	
GN 2244 see page 18 Bellows couplings		5 - 19		1.5 - 10	X	X	X	X
GN 2246 see page 20 Beam couplings		4 - 12		0.3 - 4	X	X	X	X

Couplings

Overview of types

Standard	Suitable for use with			Application examples	Special features
	Servo motors	Stepper motors	Universal motors		
GN 2240 see page 6 Elastomer jaw couplings 	X	X	X	<ul style="list-style-type: none"> - Hydraulic pumps - Packaging machines - Industrial robots - Fans - Agitators 	<ul style="list-style-type: none"> - High torques - Fast and simple plug-in assembly
GN 2241 see page 10 Elastomer jaw couplings 	X	X	X		
GN 2242 see page 14 Oldham couplings 		X	X	<ul style="list-style-type: none"> - Conveyor systems - Packaging machines - Positioning drives - Pumps 	<ul style="list-style-type: none"> - High torques - High lateral misalignment compensation - Fast and simple plug-in assembly
GN 2243 see page 16 Oldham couplings 		X	X		
GN 2244 see page 18 Bellows couplings 	X	X		<ul style="list-style-type: none"> - Rotary encoders - Position measuring systems - Test benches - Industrial robots - Spindle drives 	<ul style="list-style-type: none"> - Precise angle and torque transmission - High torsional stiffness
GN 2246 see page 20 Beam couplings 		X		<ul style="list-style-type: none"> - Confectionery machines - Industrial robots - CAT scanners - Position measuring systems 	<ul style="list-style-type: none"> - Precise angle and torque transmission - Manufactured from a single piece - High torsional stiffness

Elastomer jaw couplings

with clamping hub

SPECIFICATION

Bore codes

- Type **B**: without keyway
- Type **K**: with keyway (from $d_1 = 30$)

Hub

Aluminum **AL**
anodized, natural color

Coupling spider
Polyurethane (TPU)
temperature resistant up to 60 °C

Hardness

80 Shore A, blue **BS**

92 Shore A, white **WS**

98 Shore A, red **RS**

Socket cap screws DIN 912

Steel, blackened

Temperature range: -20 °C up to +60 °C



INFORMATION

Elastomer jaw couplings GN 2240 can transmit very high torques while compensating for shaft misalignments and runout tolerances. They are preferred in applications where the focus lies on pure torque and power transmission.

The choice of three coupling spiders with different hardness values allows the properties of the coupling to be optimally matched to the specific requirements. The clamping hubs and simple plug-in installation make jaw couplings very easy to assemble.

With the bore code K, the keyway is always integrated into both bores d_2 and d_3 .

ACCESSORY

- Coupling spiders GN 2240.1 (see page 13)

TECHNICAL INFORMATION

- Keyway P9 DIN 6885 (see main catalogue page A16)
- ISO-Fundamental Tolerances (see main catalogue page A21)
- Elastomer characteristics (see main catalogue page A32)

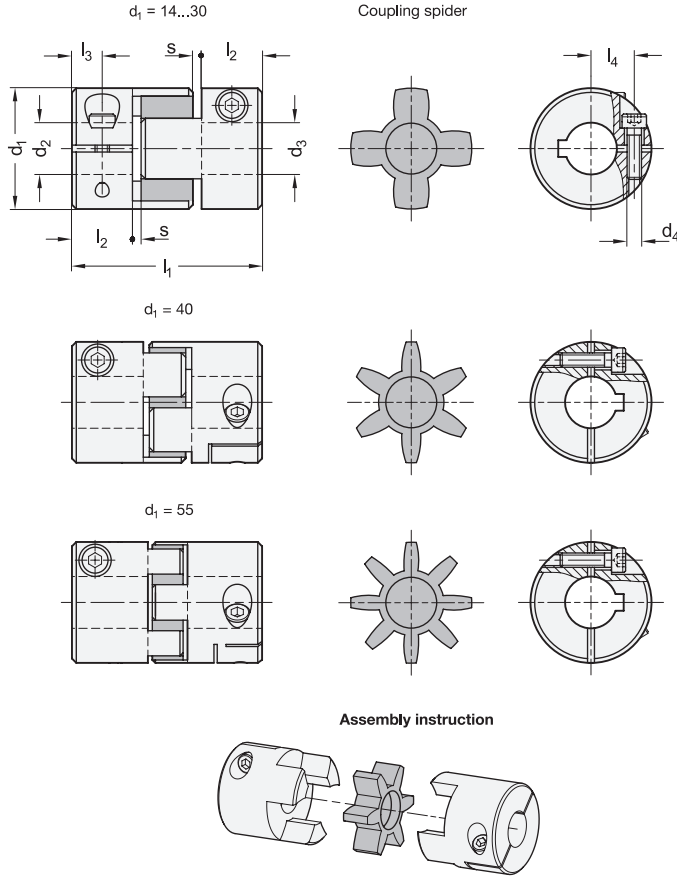

TECHNICAL VALUES

d1	Coupling spider	Shore hardness coupling spider	Rated torque in Nm	Max. torque in Nm	Max. speed (min ⁻¹)	Moment of inertia in kgm ²	Static torsional stiffness in Nm/rad	Max. shaft misalignment		
								lateral in mm	axial in mm	angular in °
14	BS	80A	0.7	1.4	45.000	2.0 × 10 ⁻⁷	8	0.15	0.6	1
14	WS	92A	1.2	2.4	45.000	2.0 × 10 ⁻⁷	14	0.1	0.6	1
14	RS	98A	2	4	45.000	2.0 × 10 ⁻⁷	22	0.1	0.6	1
20	BS	80A	1.8	3.6	31.000	1.1 × 10 ⁻⁶	16	0.2	0.8	1
20	WS	92A	3	6	31.000	1.1 × 10 ⁻⁶	29	0.15	0.8	1
20	RS	98A	5	10	31.000	1.1 × 10 ⁻⁶	55	0.1	0.8	1
30	BS	80A	4	8	21.000	6.2 × 10 ⁻⁶	46	0.2	1	1
30	WS	92A	7.5	15	21.000	6.2 × 10 ⁻⁶	73	0.15	1	1
30	RS	98A	12.5	25	21.000	6.2 × 10 ⁻⁶	130	0.1	1	1
40	BS	80A	4.9	9.8	15.000	3.7 × 10 ⁻⁵	380	0.15	1.2	1
40	WS	92A	10	20	15.000	3.7 × 10 ⁻⁵	570	0.1	1.2	1
40	RS	98A	17	34	15.000	3.7 × 10 ⁻⁵	1200	0.1	1.2	1
55	BS	80A	17	34	11.000	1.6 × 10 ⁻⁴	1400	0.2	1.4	1
55	WS	92A	35	70	11.000	1.6 × 10 ⁻⁴	1600	0.15	1.4	1
55	RS	98A	60	120	11.000	1.6 × 10 ⁻⁴	2600	0.1	1.4	1

* Complete with shore hardness of the couplings (BS, RS, WS)

BS RS WS

GN 2240-B

Description	d1	d2 - d3 H8 recommended shaft tolerance h7	d4	l1	l2 recommended shaft insertion depth	l3	l4	s recommended installation spacing	
GN 2240-14-B3-3-AL-*	14	3-3	M 2	22	7	3.5	4	1	9
GN 2240-14-B3-4-AL-*	14	3-4	M 2	22	7	3.5	4	1	9
GN 2240-14-B3-5-AL-*	14	3-5	M 2	22	7	3.5	4	1	9
GN 2240-14-B3-6-AL-*	14	3-6	M 2 / M 1.6	22	7	3.5	4 / 5	1	9
GN 2240-14-B4-4-AL-*	14	4-4	M 2	22	7	3.5	4	1	9
GN 2240-14-B4-5-AL-*	14	4-5	M 2	22	7	3.5	4	1	9
GN 2240-14-B4-6-AL-*	14	4-6	M 2 / M 1.6	22	7	3.5	4 / 5	1	9
GN 2240-14-B5-5-AL-*	14	5-5	M 2	22	7	3.5	4	1	9
GN 2240-14-B5-6-AL-*	14	5-6	M 2 / M 1.6	22	7	3.5	4 / 5	1	9
GN 2240-14-B6-6-AL-*	14	6-6	M 2 / M 1.6	22	7	3.5	4 / 5	1	9
GN 2240-20-B5-5-AL-*	20	5-5	M 2.5	30	10	5	6.5	1	22
GN 2240-20-B5-6-AL-*	20	5-6	M 2.5	30	10	5	6.5	1	22
GN 2240-20-B5-8-AL-*	20	5-8	M 2.5	30	10	5	6.5	1	22
GN 2240-20-B6-6-AL-*	20	6-6	M 2.5	30	10	5	6.5	1	22
GN 2240-20-B6-8-AL-*	20	6-8	M 2.5	30	10	5	6.5	1	22
GN 2240-20-B8-8-AL-*	20	8-8	M 2.5	30	10	5	6.5	1	22
GN 2240-30-B8-8-AL-*	30	8-8	M 4	35	11	5.5	10	1.5	51
GN 2240-30-B8-10-AL-*	30	8-10	M 4	35	11	5.5	10	1.5	51
GN 2240-30-B8-12-AL-*	30	8-12	M 4	35	11	5.5	10	1.5	51
GN 2240-30-B8-14-AL-*	30	8-14	M 4 / M 3	35	11	5.5	10 / 11	1.5	51
GN 2240-30-B10-10-AL-*	30	10-10	M 4	35	11	5.5	10	1.5	51
GN 2240-30-B10-12-AL-*	30	10-12	M 4	35	11	5.5	10	1.5	51
GN 2240-30-B10-14-AL-*	30	10-14	M 4 / M 3	35	11	5.5	10 / 11	1.5	51
GN 2240-30-B12-12-AL-*	30	12-12	M 4	35	11	5.5	10	1.5	51
GN 2240-30-B12-14-AL-*	30	12-14	M 4 / M 3	35	11	5.5	10 / 11	1.5	51
GN 2240-30-B14-14-AL-*	30	14-14	M 4 / M 3	35	11	5.5	10 / 11	1.5	51
GN 2240-40-B12-12-AL-*	40	12-12	M 5	66	25	8.5	14	2	181
GN 2240-40-B12-14-AL-*	40	12-14	M 5	66	25	8.5	14	2	181
GN 2240-40-B12-15-AL-*	40	12-15	M 5	66	25	8.5	14	2	181
GN 2240-40-B12-16-AL-*	40	12-16	M 5	66	25	8.5	14	2	181
GN 2240-40-B14-14-AL-*	40	14-14	M 5	66	25	8.5	14	2	181
GN 2240-40-B14-15-AL-*	40	14-15	M 5	66	25	8.5	14	2	181
GN 2240-40-B14-16-AL-*	40	14-16	M 5	66	25	8.5	14	2	181
GN 2240-40-B15-15-AL-*	40	15-15	M 5	66	25	8.5	14	2	181
GN 2240-40-B15-16-AL-*	40	15-16	M 5	66	25	8.5	14	2	181
GN 2240-40-B16-16-AL-*	40	16-16	M 5	66	25	8.5	14	2	181
GN 2240-55-B18-18-AL-*	55	18-18	M 6	78	30	10.5	20	2	414
GN 2240-55-B18-19-AL-*	55	18-19	M 6	78	30	10.5	20	2	414
GN 2240-55-B18-20-AL-*	55	18-20	M 6	78	30	10.5	20	2	414
GN 2240-55-B18-25-AL-*	55	18-25	M 6	78	30	10.5	20	2	414
GN 2240-55-B19-19-AL-*	55	19-19	M 6	78	30	10.5	20	2	414
GN 2240-55-B19-20-AL-*	55	19-20	M 6	78	30	10.5	20	2	414
GN 2240-55-B19-25-AL-*	55	19-25	M 6	78	30	10.5	20	2	414
GN 2240-55-B20-20-AL-*	55	20-20	M 6	78	30	10.5	20	2	414
GN 2240-55-B20-25-AL-*	55	20-25	M 6	78	30	10.5	20	2	414
GN 2240-55-B25-25-AL-*	55	25-25	M 6	78	30	10.5	20	2	414

Weight type BS

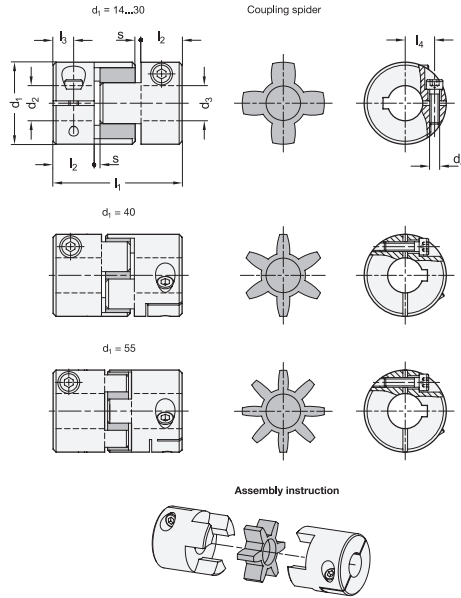

* Complete with shore hardness of the couplings (BS, RS, WS)

BS RS WS

GN 2240-K

Description	d1	d2 - d3 H8 recommended shaft tolerance h7	d4	l1	l2 recommended shaft insertion depth	l3	l4	s recommended installation spacing	⚖
GN 2240-30-K8-8-AL-*	30	8-8	M 4	35	11	5.5	10	1.5	51
GN 2240-30-K8-10-AL-*	30	8-10	M 4	35	11	5.5	10	1.5	51
GN 2240-30-K8-12-AL-*	30	8-12	M 4	35	11	5.5	10	1.5	51
GN 2240-30-K8-14-AL-*	30	8-14	M 4 / M 3	35	11	5.5	10 / 11	1.5	51
GN 2240-30-K10-10-AL-*	30	10-10	M 4	35	11	5.5	10	1.5	51
GN 2240-30-K10-12-AL-*	30	10-12	M 4	35	11	5.5	10	1.5	51
GN 2240-30-K10-14-AL-*	30	10-14	M 4 / M 3	35	11	5.5	10 / 11	1.5	51
GN 2240-30-K12-12-AL-*	30	12-12	M 4	35	11	5.5	10	1.5	51
GN 2240-30-K12-14-AL-*	30	12-14	M 4 / M 3	35	11	5.5	10 / 11	1.5	51
GN 2240-30-K14-14-AL-*	30	14-14	M 4 / M 3	35	11	5.5	10 / 11	1.5	51
GN 2240-40-K12-12-AL-*	40	12-12	M 5	66	25	8.5	14	2	181
GN 2240-40-K12-14-AL-*	40	12-14	M 5	66	25	8.5	14	2	181
GN 2240-40-K12-15-AL-*	40	12-15	M 5	66	25	8.5	14	2	181
GN 2240-40-K12-16-AL-*	40	12-16	M 5	66	25	8.5	14	2	181
GN 2240-40-K14-14-AL-*	40	14-14	M 5	66	25	8.5	14	2	181
GN 2240-40-K14-15-AL-*	40	14-15	M 5	66	25	8.5	14	2	181
GN 2240-40-K14-16-AL-*	40	14-16	M 5	66	25	8.5	14	2	181
GN 2240-40-K15-15-AL-*	40	15-15	M 5	66	25	8.5	14	2	181
GN 2240-40-K15-16-AL-*	40	15-16	M 5	66	25	8.5	14	2	181
GN 2240-40-K16-16-AL-*	40	16-16	M 5	66	25	8.5	14	2	181
GN 2240-55-K18-18-AL-*	55	18-18	M 6	78	30	10.5	20	2	414
GN 2240-55-K18-19-AL-*	55	18-19	M 6	78	30	10.5	20	2	414
GN 2240-55-K18-20-AL-*	55	18-20	M 6	78	30	10.5	20	2	414
GN 2240-55-K18-25-AL-*	55	18-25	M 6	78	30	10.5	20	2	414
GN 2240-55-K19-19-AL-*	55	19-19	M 6	78	30	10.5	20	2	414
GN 2240-55-K19-20-AL-*	55	19-20	M 6	78	30	10.5	20	2	414
GN 2240-55-K19-25-AL-*	55	19-25	M 6	78	30	10.5	20	2	414
GN 2240-55-K20-20-AL-*	55	20-20	M 6	78	30	10.5	20	2	414
GN 2240-55-K20-25-AL-*	55	20-25	M 6	78	30	10.5	20	2	414
GN 2240-55-K25-25-AL-*	55	25-25	M 6	78	30	10.5	20	2	414

Weight type BS

Elastomer jaw couplings

with grub screw

SPECIFICATION

Bore codes

- Type **B**: without keyway
- Type **K**: with keyway (from $d_1 = 30$)

Hub

Aluminum **AL**

anodized, natural color

Coupling spider

Polyurethane (TPU)

temperature resistant up to 60 °C

Hardness

80 Shore A, blue **BS**

92 Shore A, white **WS**

98 Shore A, red **RS**

Grub screws

- Steel, blackened
- for $d_2 / d_3 \leq 4$, one grub screw
- for $d_2 / d_3 > 4$, two grub screws

Temperature range: -20 °C up to +60 °C



INFORMATION

Elastomer jaw couplings GN 2241 can transmit very high torques while compensating for shaft misalignments and runout tolerances. They are preferred in applications where the focus lies on pure torque and power transmission. The choice of three coupling spiders with different hardness values allows the properties of the coupling to be optimally matched to the specific requirements. The use of grub screws for clamping and the simple plug-in installation make jaw couplings very easy to assemble. With the bore code K, the keyway is always integrated into both bores d_2 and d_3 .

ACCESSORY

- Coupling spiders GN 2240.1 (see page 13)

TECHNICAL INFORMATION

- Keyway P9 DIN 6885 (see main catalogue page A16)
- ISO-Fundamental Tolerances (see main catalogue page A21)
- Elastomer characteristics (see main catalogue page A32)

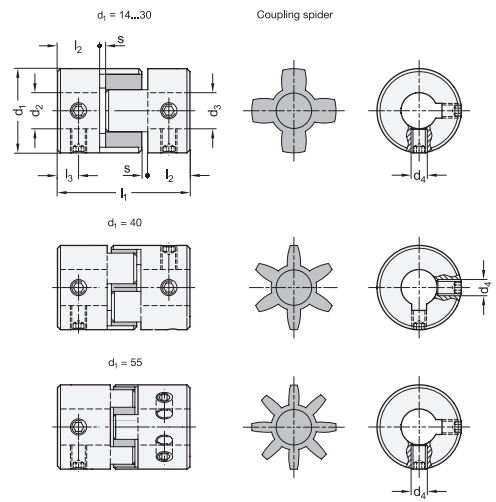

Assembly instruction

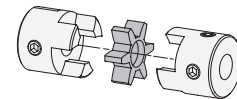

TECHNICAL VALUES

d1	Coupling spider	Shore hardness coupling spider	Rated torque in Nm	Max. torque in Nm	Max. speed (min ⁻¹)	Moment of inertia in kgm ²	Static torsional stiffness in Nm/rad	Max. shaft misalignment		
								lateral in mm	axial in mm	angular in °
14	BS	80A	0.7	1.4	45.000	2.0×10^{-7}	8	0.15	0.6	1
14	WS	92A	1.2	2.4	45.000	2.0×10^{-7}	14	0.1	0.6	1
14	RS	98A	2	4	45.000	2.0×10^{-7}	22	0.1	0.6	1
20	BS	80A	1.8	3.6	31.000	1.1×10^{-6}	16	0.2	0.8	1
20	WS	92A	3	6	31.000	1.1×10^{-6}	29	0.15	0.8	1
20	RS	98A	5	10	31.000	1.1×10^{-6}	55	0.1	0.8	1
30	BS	80A	4	8	21.000	6.2×10^{-6}	46	0.2	1	1
30	WS	92A	7.5	15	21.000	6.2×10^{-6}	73	0.15	1	1
30	RS	98A	12.5	25	21.000	6.2×10^{-6}	130	0.1	1	1
40	BS	80A	4.9	9.8	15.000	3.7×10^{-5}	380	0.15	1.2	1
40	WS	92A	10	20	15.000	3.7×10^{-5}	570	0.1	1.2	1
40	RS	98A	17	34	15.000	3.7×10^{-5}	1200	0.1	1.2	1
55	BS	80A	17	34	11.000	1.6×10^{-4}	1400	0.2	1.4	1
55	WS	92A	35	70	11.000	1.6×10^{-4}	1600	0.15	1.4	1
55	RS	98A	60	120	11.000	1.6×10^{-4}	2600	0.1	1.4	1

* Complete with shore hardness of the couplings (BS, RS, WS)

BS RS WS

GN 2241-B

Description	d1	d2 - d3 H8 recommended shaft tolerance h7	d4	l1	l2 recommended shaft insertion depth	l3	s recommended installation spacing	Tightening torque of the screw in Nm ≈	
GN 2241-14-B3-3-AL-*	14	3-3	M 3	22	7	3.5	1	0.7	9
GN 2241-14-B3-4-AL-*	14	3-4	M 3	22	7	3.5	1	0.7	9
GN 2241-14-B3-5-AL-*	14	3-5	M 3	22	7	3.5	1	0.7	9
GN 2241-14-B3-6-AL-*	14	3-6	M 3	22	7	3.5	1	0.7	9
GN 2241-14-B4-4-AL-*	14	4-4	M 3	22	7	3.5	1	0.7	9
GN 2241-14-B4-5-AL-*	14	4-5	M 3	22	7	3.5	1	0.7	9
GN 2241-14-B4-6-AL-*	14	4-6	M 3	22	7	3.5	1	0.7	9
GN 2241-14-B5-5-AL-*	14	5-5	M 3	22	7	3.5	1	0.7	9
GN 2241-14-B5-6-AL-*	14	5-6	M 3	22	7	3.5	1	0.7	9
GN 2241-14-B6-6-AL-*	14	6-6	M 3	22	7	3.5	1	0.7	9
GN 2241-20-B5-5-AL-*	20	5-5	M 3	30	10	5	1	0.7	22
GN 2241-20-B5-6-AL-*	20	5-6	M 3	30	10	5	1	0.7	22
GN 2241-20-B5-8-AL-*	20	5-8	M 3	30	10	5	1	0.7	22
GN 2241-20-B6-6-AL-*	20	6-6	M 3	30	10	5	1	0.7	22
GN 2241-20-B6-8-AL-*	20	6-8	M 3	30	10	5	1	0.7	22
GN 2241-20-B8-8-AL-*	20	8-8	M 3	30	10	5	1	0.7	22
GN 2241-30-B8-8-AL-*	30	8-8	M 4	35	11	5.5	1.5	1.7	53
GN 2241-30-B8-10-AL-*	30	8-10	M 4	35	11	5.5	1.5	1.7	53
GN 2241-30-B8-12-AL-*	30	8-12	M 4	35	11	5.5	1.5	1.7	53
GN 2241-30-B8-14-AL-*	30	8-14	M 4	35	11	5.5	1.5	1.7	53
GN 2241-30-B10-10-AL-*	30	10-10	M 4	35	11	5.5	1.5	1.7	53
GN 2241-30-B10-12-AL-*	30	10-12	M 4	35	11	5.5	1.5	1.7	53
GN 2241-30-B10-14-AL-*	30	10-14	M 4	35	11	5.5	1.5	1.7	53
GN 2241-30-B12-12-AL-*	30	12-12	M 4	35	11	5.5	1.5	1.7	53
GN 2241-30-B12-14-AL-*	30	12-14	M 4	35	11	5.5	1.5	1.7	53
GN 2241-30-B14-14-AL-*	30	14-14	M 4	35	11	5.5	1.5	1.7	53
GN 2241-40-B12-12-AL-*	40	12-12	M 5	66	25	8.5	2	4	193
GN 2241-40-B12-14-AL-*	40	12-14	M 5	66	25	8.5	2	4	193
GN 2241-40-B12-15-AL-*	40	12-15	M 5	66	25	8.5	2	4	193
GN 2241-40-B12-16-AL-*	40	12-16	M 5	66	25	8.5	2	4	193
GN 2241-40-B14-14-AL-*	40	14-14	M 5	66	25	8.5	2	4	193
GN 2241-40-B14-15-AL-*	40	14-15	M 5	66	25	8.5	2	4	193
GN 2241-40-B14-16-AL-*	40	14-16	M 5	66	25	8.5	2	4	193
GN 2241-40-B15-15-AL-*	40	15-15	M 5	66	25	8.5	2	4	193
GN 2241-40-B15-16-AL-*	40	15-16	M 5	66	25	8.5	2	4	193
GN 2241-40-B16-16-AL-*	40	16-16	M 5	66	25	8.5	2	4	193
GN 2241-55-B18-18-AL-*	55	18-18	M 6	78	30	10.5	2	7	436
GN 2241-55-B18-19-AL-*	55	18-19	M 6	78	30	10.5	2	7	436
GN 2241-55-B18-20-AL-*	55	18-20	M 6	78	30	10.5	2	7	436
GN 2241-55-B18-25-AL-*	55	18-25	M 6	78	30	10.5	2	7	436
GN 2241-55-B19-19-AL-*	55	19-19	M 6	78	30	10.5	2	7	436
GN 2241-55-B19-20-AL-*	55	19-20	M 6	78	30	10.5	2	7	436
GN 2241-55-B19-25-AL-*	55	19-25	M 6	78	30	10.5	2	7	436
GN 2241-55-B20-20-AL-*	55	20-20	M 6	78	30	10.5	2	7	436
GN 2241-55-B20-25-AL-*	55	20-25	M 6	78	30	10.5	2	7	436
GN 2241-55-B25-25-AL-*	55	25-25	M 6	78	30	10.5	2	7	436

Weight type BS

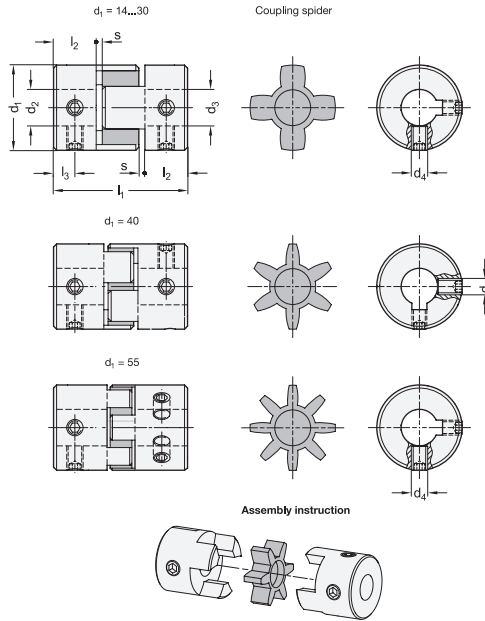

* Complete with shore hardness of the couplings (BS, RS, WS)

BS RS WS

GN 2241-K

Description	d1	d2 - d3 H8 recommended shaft tolerance h7	d4	l1	l2 recommended shaft insertion depth	l3	s recommended installation spacing	Tightening torque of the screw in Nm ≈	⚖
GN 2241-30-K8-8-AL-*	30	8-8	M 4	35	11	5.5	1.5	1.7	53
GN 2241-30-K8-10-AL-*	30	8-10	M 4	35	11	5.5	1.5	1.7	53
GN 2241-30-K8-12-AL-*	30	8-12	M 4	35	11	5.5	1.5	1.7	53
GN 2241-30-K8-14-AL-*	30	8-14	M 4	35	11	5.5	1.5	1.7	53
GN 2241-30-K10-10-AL-*	30	10-10	M 4	35	11	5.5	1.5	1.7	53
GN 2241-30-K10-12-AL-*	30	10-12	M 4	35	11	5.5	1.5	1.7	53
GN 2241-30-K10-14-AL-*	30	10-14	M 4	35	11	5.5	1.5	1.7	53
GN 2241-30-K12-12-AL-*	30	12-12	M 4	35	11	5.5	1.5	1.7	53
GN 2241-30-K12-14-AL-*	30	12-14	M 4	35	11	5.5	1.5	1.7	53
GN 2241-30-K14-14-AL-*	30	14-14	M 4	35	11	5.5	1.5	1.7	53
GN 2241-40-K12-12-AL-*	40	12-12	M 5	66	25	8.5	2	4	193
GN 2241-40-K12-14-AL-*	40	12-14	M 5	66	25	8.5	2	4	193
GN 2241-40-K12-15-AL-*	40	12-15	M 5	66	25	8.5	2	4	193
GN 2241-40-K12-16-AL-*	40	12-16	M 5	66	25	8.5	2	4	193
GN 2241-40-K14-14-AL-*	40	14-14	M 5	66	25	8.5	2	4	193
GN 2241-40-K14-15-AL-*	40	14-15	M 5	66	25	8.5	2	4	193
GN 2241-40-K14-16-AL-*	40	14-16	M 5	66	25	8.5	2	4	193
GN 2241-40-K15-15-AL-*	40	15-15	M 5	66	25	8.5	2	4	193
GN 2241-40-K15-16-AL-*	40	15-16	M 5	66	25	8.5	2	4	193
GN 2241-40-K16-16-AL-*	40	16-16	M 5	66	25	8.5	2	4	193
GN 2241-55-K18-18-AL-*	55	18-18	M 6	78	30	10.5	2	7	436
GN 2241-55-K18-19-AL-*	55	18-19	M 6	78	30	10.5	2	7	436
GN 2241-55-K18-20-AL-*	55	18-20	M 6	78	30	10.5	2	7	436
GN 2241-55-K18-25-AL-*	55	18-25	M 6	78	30	10.5	2	7	436
GN 2241-55-K19-19-AL-*	55	19-19	M 6	78	30	10.5	2	7	436
GN 2241-55-K19-20-AL-*	55	19-20	M 6	78	30	10.5	2	7	436
GN 2241-55-K19-25-AL-*	55	19-25	M 6	78	30	10.5	2	7	436
GN 2241-55-K20-20-AL-*	55	20-20	M 6	78	30	10.5	2	7	436
GN 2241-55-K20-25-AL-*	55	20-25	M 6	78	30	10.5	2	7	436
GN 2241-55-K25-25-AL-*	55	25-25	M 6	78	30	10.5	2	7	436

Weight type BS

Coupling spiders

for GN 2240 / GN 2241

SPECIFICATION

Polyurethane (TPU)
temperature resistant up to 60 °C

Hardness

80 Shore A, blue **BS**

92 Shore A, white **WS**

98 Shore A, red **RS**

INFORMATION

Coupling spiders GN 2240.1 are intended as replacement parts or for adjusting elastomer jaw couplings GN 2240 (see page 6) / GN 2241 (see page 10).

The choice of three coupling spiders with different hardness values allows the properties of the coupling to be optimally matched to the specific requirements.



TECHNICAL INFORMATION

- Elastomer characteristics (see main catalogue page A32)

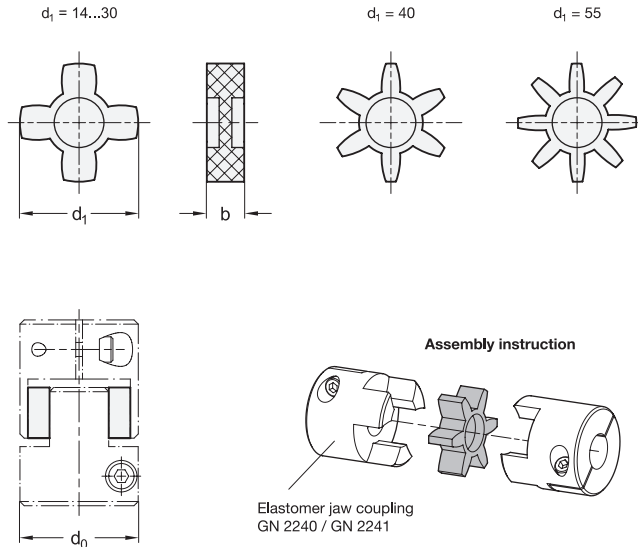

GN 2240.1

Description	d0 Coupling Ø GN 2240 / GN 2241	d1	b	Number of teeth	⚖
GN 2240.1-14-BS	14	14	6	4	1
GN 2240.1-14-RS	14	14	6	4	1
GN 2240.1-14-WS	14	14	6	4	1
GN 2240.1-20-BS	20	20	8	4	2
GN 2240.1-20-RS	20	20	8	4	2
GN 2240.1-20-WS	20	20	8	4	2
GN 2240.1-30-BS	30	30	10	4	5
GN 2240.1-30-RS	30	30	10	4	5
GN 2240.1-30-WS	30	30	10	4	5
GN 2240.1-40-BS	40	40	12	6	7
GN 2240.1-40-RS	40	40	12	6	7
GN 2240.1-40-WS	40	40	12	6	7
GN 2240.1-55-BS	55	55	14	8	18
GN 2240.1-55-RS	55	55	14	8	18
GN 2240.1-55-WS	55	55	14	8	18

Oldham couplings

with clamping hub

SPECIFICATION

Bore codes

- Type **B**: without keyway
- Type **K**: with keyway (from $d_1 = 20$)

Hub

Aluminum **AL**

anodized, natural color

Spacer

Plastic (Polyacetal POM) **KU**

temperature resistant up to 80 °C

Socket cap screws DIN 912

Steel, blackened

Temperature range: -20 °C up to +80 °C



INFORMATION

Oldham couplings GN 2242 can compensate for large lateral shaft misalignments while transmitting high torques. As a result, they are used in applications with a focus on pure torque and power transmission associated with high lateral shaft misalignments.

The clamping hubs and simple plug-in installation make oldham couplings very easy to assemble. They are suitable for a diverse range of applications and are used in general machine construction in packaging machines and pumps.

With the bore code K, the keyway is always integrated into both bores d_2 and d_3 .

TECHNICAL INFORMATION

- Keyway P9 DIN 6885 (see main catalogue page A16)
- ISO-Fundamental Tolerances (see main catalogue page A21)
- Plastic characteristics (see main catalogue page A2)

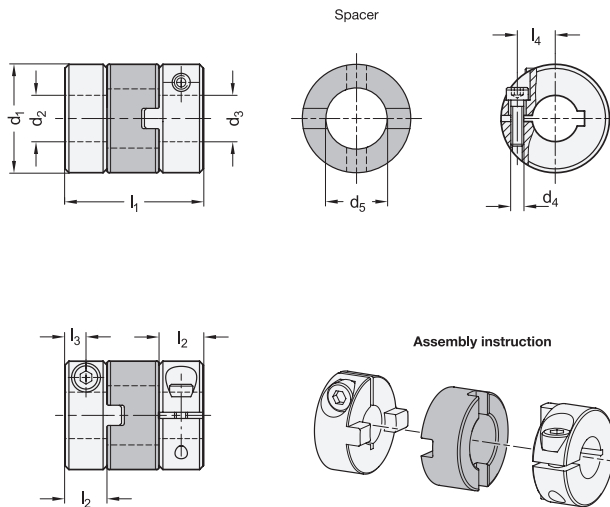

TECHNICAL VALUES

d1	Rated torque in Nm*	Max. torque in Nm	Max. speed (min ⁻¹)	Moment of inertia in kgm ²	Static torsional stiffness in Nm/rad	Max. shaft misalignment	
						lateral in mm	angular in °
12	1	2	52.000	6.6×10^{-8}	60	1	3
15	1.6	3.2	42.000	1.7×10^{-7}	80	1	3
20	3.2	6.4	31.000	8.0×10^{-7}	120	1.2	3
30	15	30	21.000	5.2×10^{-6}	530	2	3
38	28	56	16.000	1.5×10^{-5}	1500	2.5	3

*Load fluctuations are not taken into account

GN 2242-B

Description	d1	d2 - d3 H8 recommended shaft tolerance h7	d4	d5	l1	l2 recommended shaft insertion depth	l3	l4	
GN 2242-12-B4-4-AL-KU	12	4-4	M 2	5.2	19	6.2	3.1	4	3
GN 2242-12-B4-5-AL-KU	12	4-5	M 2	5.2	19	6.2	3.1	4	3
GN 2242-12-B5-5-AL-KU	12	5-5	M 2	5.2	19	6.2	3.1	4	3
GN 2242-15-B4-4-AL-KU	15	4-4	M 2.5	8.2	21.2	7	3.5	5	6
GN 2242-15-B4-5-AL-KU	15	4-5	M 2.5	8.2	21.2	7	3.5	5	6
GN 2242-15-B4-6-AL-KU	15	4-6	M 2.5	8.2	21.2	7	3.5	5	6
GN 2242-15-B5-5-AL-KU	15	5-5	M 2.5	8.2	21.2	7	3.5	5	6
GN 2242-15-B5-6-AL-KU	15	5-6	M 2.5	8.2	21.2	7	3.5	5	6
GN 2242-15-B6-6-AL-KU	15	6-6	M 2.5	8.2	21.2	7	3.5	5	6
GN 2242-20-B6-6-AL-KU	20	6-6	M 3	12.2	27	8.8	4.4	7.5	13
GN 2242-20-B6-8-AL-KU	20	6-8	M 3	12.2	27	8.8	4.4	7.5	13
GN 2242-20-B6-10-AL-KU	20	6-10	M 3	12.2	27	8.8	4.4	7.5	13
GN 2242-20-B8-8-AL-KU	20	8-8	M 3	12.2	27	8.8	4.4	7.5	13
GN 2242-20-B8-10-AL-KU	20	8-10	M 3	12.2	27	8.8	4.4	7.5	13
GN 2242-20-B10-10-AL-KU	20	10-10	M 3	12.2	27	8.8	4.4	7.5	13
GN 2242-30-B8-8-AL-KU	30	8-8	M 4	16.2	32.5	10	5	11.1	44
GN 2242-30-B8-10-AL-KU	30	8-10	M 4	16.2	32.5	10	5	11.1	44
GN 2242-30-B8-12-AL-KU	30	8-12	M 4	16.2	32.5	10	5	11.1	44
GN 2242-30-B10-10-AL-KU	30	10-10	M 4	16.2	32.5	10	5	11.1	44
GN 2242-30-B10-12-AL-KU	30	10-12	M 4	16.2	32.5	10	5	11.1	44
GN 2242-30-B12-12-AL-KU	30	12-12	M 4	16.2	32.5	10	5	11.1	44
GN 2242-38-B12-12-AL-KU	38	12-12	M 5	20.3	40	12.1	6	14.2	76
GN 2242-38-B12-15-AL-KU	38	12-15	M 5	20.3	40	12.1	6	14.2	76
GN 2242-38-B12-20-AL-KU	38	12-20	M 5	20.3	40	12.1	6	14.2	76
GN 2242-38-B15-15-AL-KU	38	15-15	M 5	20.3	40	12.1	6	14.2	76
GN 2242-38-B15-20-AL-KU	38	15-20	M 5	20.3	40	12.1	6	14.2	76
GN 2242-38-B20-20-AL-KU	38	20-20	M 5	20.3	40	12.1	6	14.2	76

GN 2242-K

Description	d1	d2 - d3 H8 recommended shaft tolerance h7	d4	d5	l1	l2 recommended shaft insertion depth	l3	l4	
GN 2242-20-K6-6-AL-KU	20	6-6	M 3	12.2	27	8.8	4.4	7.5	13
GN 2242-20-K6-8-AL-KU	20	6-8	M 3	12.2	27	8.8	4.4	7.5	13
GN 2242-20-K6-10-AL-KU	20	6-10	M 3	12.2	27	8.8	4.4	7.5	13
GN 2242-20-K8-8-AL-KU	20	8-8	M 3	12.2	27	8.8	4.4	7.5	13
GN 2242-20-K8-10-AL-KU	20	8-10	M 3	12.2	27	8.8	4.4	7.5	13
GN 2242-20-K10-10-AL-KU	20	10-10	M 3	12.2	27	8.8	4.4	7.5	13
GN 2242-30-K8-8-AL-KU	30	8-8	M 4	16.2	32.5	10	5	11.1	44
GN 2242-30-K8-10-AL-KU	30	8-10	M 4	16.2	32.5	10	5	11.1	44
GN 2242-30-K8-12-AL-KU	30	8-12	M 4	16.2	32.5	10	5	11.1	44
GN 2242-30-K10-10-AL-KU	30	10-10	M 4	16.2	32.5	10	5	11.1	44
GN 2242-30-K10-12-AL-KU	30	10-12	M 4	16.2	32.5	10	5	11.1	44
GN 2242-30-K12-12-AL-KU	30	12-12	M 4	16.2	32.5	10	5	11.1	44
GN 2242-38-K12-12-AL-KU	38	12-12	M 5	20.3	40	12.1	6	14.2	76
GN 2242-38-K12-15-AL-KU	38	12-15	M 5	20.3	40	12.1	6	14.2	76
GN 2242-38-K12-20-AL-KU	38	12-20	M 5	20.3	40	12.1	6	14.2	76
GN 2242-38-K15-15-AL-KU	38	15-15	M 5	20.3	40	12.1	6	14.2	76
GN 2242-38-K15-20-AL-KU	38	15-20	M 5	20.3	40	12.1	6	14.2	76
GN 2242-38-K20-20-AL-KU	38	20-20	M 5	20.3	40	12.1	6	14.2	76

Oldham couplings

with grub screw

SPECIFICATION

Bore codes

- Type **B**: without keyway
- Type **K**: with keyway (from $d_1 = 20$)

Hub

Aluminum **AL**

anodized, natural color

Spacer

Plastic (Polyacetal) POM **KU**

temperature resistant up to 80 °C

Grub screws

- Steel, blackened
- for $d_2 / d_3 \leq 4$, one grub screw
- for $d_2 / d_3 > 4$, two grub screws

Temperature range: -20 °C up to +80 °C



INFORMATION

Oldham couplings GN 2243 can compensate for large lateral shaft misalignments while transmitting high torques. As a result, they are used in applications with a focus on pure torque and power transmission associated with high lateral shaft misalignments.

The use of grub screws for clamping and the simple plug-in installation make oldham couplings very easy to assemble. They are suitable for a diverse range of applications and are used in general machine construction in packaging machines and pumps.

With the bore code K, the keyway is always integrated into both bores d_2 and d_3 .

TECHNICAL INFORMATION

- Keyway P9 DIN 6885 (see main catalogue page A16)
- ISO-Fundamental Tolerances (see main catalogue page A21)
- Elastomer characteristics (see main catalogue page A32)

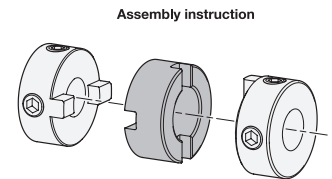
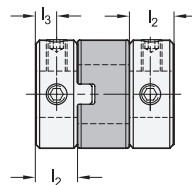
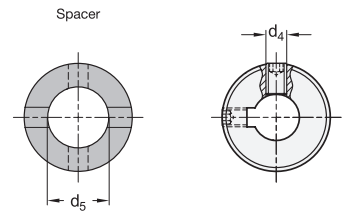
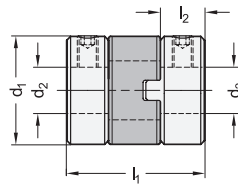

TECHNICAL VALUES

d1	Rated torque in Nm*	Max. torque in Nm*	Max. speed (min ⁻¹)	Moment of inertia in kgm ²	Static torsional stiffness in Nm/rad	Max. shaft misalignment	
						lateral in mm	angular in °
8	0.5	1	78.000	7.4×10^{-9}	12	0.7	3
12	1	2	52.000	5.3×10^{-8}	60	1	3
38	1.6	3.2	42.000	1.4×10^{-7}	80	1	3
20	3.2	6.4	31.000	5.7×10^{-7}	120	1.2	3
30	15	30	21.000	5.4×10^{-6}	530	2	3
38	28	56	16.000	1.6×10^{-5}	1500	2.5	3

* Load fluctuations are not taken into account

GN 2243-B

Description	d1	d2 - d3 H8 recommended shaft tolerance h7	d4	d5	l1	l2 recommended shaft insertion depth	l3	Tightening torque of the screw in Nm \approx	
GN 2243-8-B2-2-AL-KU	8	2-2	M 2	3.1	9.6	2.5	1.3	0.3	3
GN 2243-8-B2-3-AL-KU	8	2-3	M 2	3.1	9.6	2.5	1.3	0.3	3
GN 2243-8-B3-3-AL-KU	8	3-3	M 2	3.1	9.6	2.5	1.3	0.3	3
GN 2243-12-B4-4-AL-KU	12	4-4	M 3	5.2	14.2	3.9	2	0.7	3
GN 2243-12-B4-5-AL-KU	12	4-5	M 3	5.2	14.2	3.9	2	0.7	3
GN 2243-12-B5-5-AL-KU	12	5-5	M 3	5.2	14.2	3.9	2	0.7	3
GN 2243-15-B4-4-AL-KU	15	4-4	M 3	8.2	16	4.4	2.2	0.7	6
GN 2243-15-B4-5-AL-KU	15	4-5	M 3	8.2	16	4.4	2.2	0.7	6
GN 2243-15-B4-6-AL-KU	15	4-6	M 3	8.2	16	4.4	2.2	0.7	6
GN 2243-15-B5-5-AL-KU	15	5-5	M 3	8.2	16	4.4	2.2	0.7	6
GN 2243-15-B5-6-AL-KU	15	5-6	M 3	8.2	16	4.4	2.2	0.7	6
GN 2243-15-B6-6-AL-KU	15	6-6	M 3	8.2	16	4.4	2.2	0.7	6
GN 2243-20-B6-6-AL-KU	20	6-6	M 4	12.2	21.4	5.8	2.9	1.7	11
GN 2243-20-B6-8-AL-KU	20	6-8	M 4	12.2	21.4	5.8	2.9	1.7	11
GN 2243-20-B6-10-AL-KU	20	6-10	M 4	12.2	21.4	5.8	2.9	1.7	11
GN 2243-20-B8-8-AL-KU	20	8-8	M 4	12.2	21.4	5.8	2.9	1.7	11
GN 2243-20-B8-10-AL-KU	20	8-10	M 4	12.2	21.4	5.8	2.9	1.7	11
GN 2243-20-B10-10-AL-KU	20	10-10	M 4	12.2	21.4	5.8	2.9	1.7	11
GN 2243-30-B8-8-AL-KU	30	8-8	M 4	16.2	32.5	10	5	1.7	40
GN 2243-30-B8-10-AL-KU	30	8-10	M 4	16.2	32.5	10	5	1.7	40
GN 2243-30-B8-12-AL-KU	30	8-12	M 4	16.2	32.5	10	5	1.7	40
GN 2243-30-B10-10-AL-KU	30	10-10	M 4	16.2	32.5	10	5	1.7	40
GN 2243-30-B10-12-AL-KU	30	10-12	M 4	16.2	32.5	10	5	1.7	40
GN 2243-30-B12-12-AL-KU	30	12-12	M 4	16.2	32.5	10	5	1.7	40
GN 2243-38-B12-12-AL-KU	38	12-12	M 5	20.3	40	12.1	6.1	4	76
GN 2243-38-B12-15-AL-KU	38	12-15	M 5	20.3	40	12.1	6.1	4	76
GN 2243-38-B12-20-AL-KU	38	12-20	M 5	20.3	40	12.1	6.1	4	76
GN 2243-38-B15-15-AL-KU	38	15-15	M 5	20.3	40	12.1	6.1	4	76
GN 2243-38-B15-20-AL-KU	38	15-20	M 5	20.3	40	12.1	6.1	4	76
GN 2243-38-B20-20-AL-KU	38	20-20	M 5	20.3	40	12.1	6.1	4	76

GN 2243-K

Description	d1	d2 - d3 H8 recommended shaft tolerance h7	d4	d5	l1	l2 recommended shaft insertion depth	l3	Tightening torque of the screw in Nm \approx	
GN 2243-20-K6-6-AL-KU	20	6-6	M 4	12.2	21.4	5.8	2.9	1.7	11
GN 2243-20-K6-8-AL-KU	20	6-8	M 4	12.2	21.4	5.8	2.9	1.7	11
GN 2243-20-K6-10-AL-KU	20	6-10	M 4	12.2	21.4	5.8	2.9	1.7	11
GN 2243-20-K8-8-AL-KU	20	8-8	M 4	12.2	21.4	5.8	2.9	1.7	11
GN 2243-20-K8-10-AL-KU	20	8-10	M 4	12.2	21.4	5.8	2.9	1.7	11
GN 2243-20-K10-10-AL-KU	20	10-10	M 4	12.2	21.4	5.8	2.9	1.7	11
GN 2243-30-K8-8-AL-KU	30	8-8	M 4	16.2	32.5	10	5	1.7	40
GN 2243-30-K8-10-AL-KU	30	8-10	M 4	16.2	32.5	10	5	1.7	40
GN 2243-30-K8-12-AL-KU	30	8-12	M 4	16.2	32.5	10	5	1.7	40
GN 2243-30-K10-10-AL-KU	30	10-10	M 4	16.2	32.5	10	5	1.7	40
GN 2243-30-K10-12-AL-KU	30	10-12	M 4	16.2	32.5	10	5	1.7	40
GN 2243-30-K12-12-AL-KU	30	12-12	M 4	16.2	32.5	10	5	1.7	40
GN 2243-38-K12-12-AL-KU	38	12-12	M 5	20.3	40	12.1	6.1	4	76
GN 2243-38-K12-15-AL-KU	38	12-15	M 5	20.3	40	12.1	6.1	4	76
GN 2243-38-K12-20-AL-KU	38	12-20	M 5	20.3	40	12.1	6.1	4	76
GN 2243-38-K15-15-AL-KU	38	15-15	M 5	20.3	40	12.1	6.1	4	76
GN 2243-38-K15-20-AL-KU	38	15-20	M 5	20.3	40	12.1	6.1	4	76
GN 2243-38-K20-20-AL-KU	38	20-20	M 5	20.3	40	12.1	6.1	4	76

Bellows couplings

with clamping hub

SPECIFICATION

Bore code

Type **B**: without keyway

Hub

Aluminum **AL**

anodized, natural color

Bellows

Stainless Steel AISI 304 **NI**

Socket cap screws DIN 912

Steel, blackened

Crimp ring

Brass

Temperature resistant up to 120 °C



INFORMATION

Bellows couplings GN 2244 transmit angle positions and torques with extreme precision and zero backlash. The metal bellows also reliably compensates for shaft misalignments and runout tolerances. The clamping hubs make bellows couplings very easy to install.

They are used in applications where precise position and movement transmission is required, such as in the servo drive systems of machine tools and in industrial robots.

TECHNICAL INFORMATION

- ISO-Fundamental Tolerances (see main catalogue page A21)
- Stainless Steel characteristics (see main catalogue page A26)

ON REQUEST

- Bore with keyway

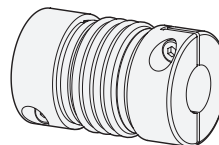
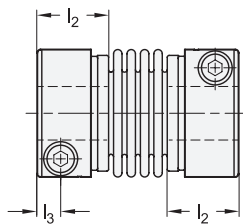
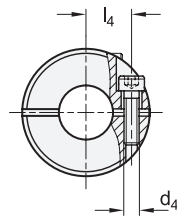
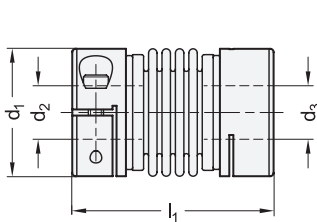

TECHNICAL VALUES

d1	Rated torque in Nm	Max. speed (min ⁻¹)	Moment of inertia in kgm ²	Static torsional stiffness in Nm/rad	Max. shaft misalignment		
					lateral in mm	axial in mm	angular in°
19	1.5	33.000	8.6×10^{-7}	170	0.15	± 0.5	1.5
27	2.3	23.000	3.6×10^{-6}	800	0.15	± 0.5	1.5
32	4.5	19.000	1.1×10^{-6}	1600	0.2	± 0.7	1.5
40	10	15.000	2.8×10^{-5}	2700	0.2	± 1	1.5

Description	d1	d2 - d3 H8 recommended shaft tolerance h7	d4	l1	l2 recommended shaft insertion depth	l3	l4	Tightening torque of the screw in Nm ≈	
GN 2244-19-B5-5-AL-NI	19	5-5	M 2	30	10.5	3	6.8	0.5	16
GN 2244-19-B5-6-AL-NI	19	5-6	M 2	30	10.5	3	6.8	0.5	16
GN 2244-19-B5-8-AL-NI	19	5-8	M 2	30	10.5	3	6.8	0.5	16
GN 2244-19-B6-6-AL-NI	19	6-6	M 2	30	10.5	3	6.8	0.5	16
GN 2244-19-B6-8-AL-NI	19	6-8	M 2	30	10.5	3	6.8	0.5	16
GN 2244-19-B8-8-AL-NI	19	8-8	M 2	30	10.5	3	6.8	0.5	16
GN 2244-27-B6-6-AL-NI	27	6-6	M 2.5	35	12.5	3.5	10.3	0.9	32
GN 2244-27-B6-8-AL-NI	27	6-8	M 2.5	35	12.5	3.5	10.3	0.9	32
GN 2244-27-B6-10-AL-NI	27	6-10	M 2.5	35	12.5	3.5	10.3	0.9	32
GN 2244-27-B8-8-AL-NI	27	8-8	M 2.5	35	12.5	3.5	10.3	0.9	32
GN 2244-27-B8-10-AL-NI	27	8-10	M 2.5	35	12.5	3.5	10.3	0.9	32
GN 2244-27-B10-10-AL-NI	27	10-10	M 2.5	35	12.5	3.5	10.3	0.9	32
GN 2244-32-B10-10-AL-NI	32	10-10	M 3	46	15.5	4.3	12	1.5	68
GN 2244-32-B10-12-AL-NI	32	10-12	M 3	46	15.5	4.3	12	1.5	68
GN 2244-32-B10-14-AL-NI	32	10-14	M 3	46	15.5	4.3	12	1.5	68
GN 2244-32-B12-12-AL-NI	32	12-12	M 3	46	15.5	4.3	12	1.5	68
GN 2244-32-B12-14-AL-NI	32	12-14	M 3	46	15.5	4.3	12	1.5	68
GN 2244-32-B14-14-AL-NI	32	14-14	M 3	46	15.5	4.3	12	1.5	68
GN 2244-40-B12-12-AL-NI	40	12-12	M 4	51	16	5	15	3.5	110
GN 2244-40-B12-15-AL-NI	40	12-15	M 4	51	16	5	15	3.5	110
GN 2244-40-B12-19-AL-NI	40	12-19	M 4	51	16	5	15	3.5	110
GN 2244-40-B15-15-AL-NI	40	15-15	M 4	51	16	5	15	3.5	110
GN 2244-40-B15-19-AL-NI	40	15-19	M 4	51	16	5	15	3.5	110
GN 2244-40-B19-19-AL-NI	40	19-19	M 4	51	16	5	15	3.5	110

Beam couplings

Aluminum / Stainless Steel, with clamping hub

SPECIFICATION

Bore code

Type **B**: without keyway

Version in Aluminum **AL**

- anodized, natural color
- temperature resistant up to 150 °C
- Socket cap screws DIN 912, Steel blackened

Version in Stainless Steel **NI**

- AISI 303
- temperature resistant up to 200 °C
- Socket cap screws DIN 912, Stainless Steel AISI 304 Cu

INFORMATION

Beam couplings GN 2246 transmit angle positions and torques with extreme precision and no backlash. They are manufactured of a single piece and offer high torsional stiffness thanks to the alternating slits. The clamping hubs make beam couplings very easy to assemble.

They are used in applications where precise position and movement transmission is required, such as in the drive systems of position measuring systems and in test benches.

The Stainless Steel version can also be used in environments requiring high corrosion resistance, such as in medical technology (CAT scanners) and food-processing equipment (confectionary machines).

TECHNICAL INFORMATION

- ISO-Fundamental Tolerances (see main catalogue page A21)
- Stainless Steel characteristics (see main catalogue page A26)

ON REQUEST

- Bore with keyway

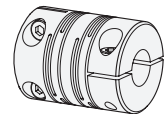
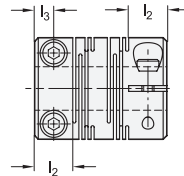
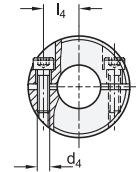
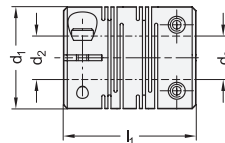

TECHNICAL VALUES

Version in Aluminum

d1	Rated torque in Nm	Max. speed (min ⁻¹)	Moment of inertia in kgm ²	Static torsional stiffness in Nm/rad	Max. shaft misalignment		
					lateral in mm	axial in mm	angular in °
12	0.4	52.000	7.8×10^{-8}	45	0.1	± 0.3	2
16	0.5	39.000	3.4×10^{-7}	80	0.1	± 0.4	2
20	1	31.000	9.1×10^{-7}	170	0.1	± 0.4	2
25	2	25.000	2.6×10^{-6}	380	0.15	± 0.4	2
32	4	19.000	9.7×10^{-6}	500	0.15	± 0.5	2

Version in Stainless Steel

d1	Rated torque in Nm	Max. speed (min ⁻¹)	Moment of inertia in kgm ²	Static torsional stiffness in Nm/rad	Max. shaft misalignment		
					lateral in mm	axial in mm	angular in °
12	0.3	52.000	2.2×10^{-7}	64	0.1	± 0.2	2
16	0.5	39.000	9.0×10^{-7}	85	0.1	± 0.3	2
20	1	31.000	2.5×10^{-6}	250	0.1	± 0.3	2
25	2	25.000	7.1×10^{-6}	330	0.15	± 0.4	2
32	3.5	19.000	2.7×10^{-5}	850	0.15	± 0.5	2

GN 2246-AL

Description	d1	d2 - d3 H8 recommended shaft tolerance h7	d4	l1	l2 recommended shaft insertion depth	l3	l4	Tightening torque of the screw in Nm ≈	
GN 2246-12-B4-4-AL	12	4-4	M 2	18.5	5	2.5	4	0.5	4
GN 2246-12-B4-5-AL	12	4-5	M 2	18.5	5	2.5	4	0.5	4
GN 2246-12-B5-5-AL	12	5-5	M 2	18.5	5	2.5	4	0.5	4
GN 2246-16-B5-5-AL	16	5-5	M 2.5	23	6.5	3.25	5	1	9
GN 2246-16-B5-6-AL	16	5-6	M 2.5	23	6.5	3.25	5	1	9
GN 2246-16-B6-6-AL	16	6-6	M 2.5	23	6.5	3.25	5	1	9
GN 2246-20-B5-5-AL	20	5-5	M 2.5	26	7.5	3.75	6.5	1	16
GN 2246-20-B5-6-AL	20	5-6	M 2.5	26	7.5	3.75	6.5	1	16
GN 2246-20-B5-8-AL	20	5-8	M 2.5	26	7.5	3.75	6.5	1	16
GN 2246-20-B6-6-AL	20	6-6	M 2.5	26	7.5	3.75	6.5	1	16
GN 2246-20-B6-8-AL	20	6-8	M 2.5	26	7.5	3.75	6.5	1	16
GN 2246-20-B8-8-AL	20	8-8	M 2.5	26	7.5	3.75	6.5	1	16
GN 2246-25-B6-6-AL	25	6-6	M 3	31	8.5	4.25	9	1.5	28
GN 2246-25-B6-8-AL	25	6-8	M 3	31	8.5	4.25	9	1.5	28
GN 2246-25-B6-10-AL	25	6-10	M 3	31	8.5	4.25	9	1.5	28
GN 2246-25-B8-8-AL	25	8-8	M 3	31	8.5	4.25	9	1.5	28
GN 2246-25-B8-10-AL	25	8-10	M 3	31	8.5	4.25	9	1.5	28
GN 2246-25-B10-10-AL	25	10-10	M 3	31	8.5	4.25	9	1.5	28
GN 2246-32-B10-10-AL	32	10-10	M 4	41	12	6	11	2.5	64
GN 2246-32-B10-12-AL	32	10-12	M 4	41	12	6	11	2.5	64
GN 2246-32-B12-12-AL	32	12-12	M 4	41	12	6	11	2.5	64

GN 2246-NI

STAINLESS STEEL

Description	d1	d2 - d3 H8 recommended shaft tolerance h7	d4	l1	l2 recommended shaft insertion depth	l3	l4	Tightening torque of the screw in Nm ≈	
GN 2246-12-B4-4-NI	12	4-4	M 2	18.5	5	2.5	4	0.5	10
GN 2246-12-B4-5-NI	12	4-5	M 2	18.5	5	2.5	4	0.5	10
GN 2246-12-B5-5-NI	12	5-5	M 2	18.5	5	2.5	4	0.5	10
GN 2246-16-B5-5-NI	16	5-5	M 2.5	23	6.5	3.25	5	1	25
GN 2246-16-B5-6-NI	16	5-6	M 2.5	23	6.5	3.25	5	1	25
GN 2246-16-B6-6-NI	16	6-6	M 2.5	23	6.5	3.25	5	1	25
GN 2246-20-B5-5-NI	20	5-5	M 2.5	26	7.5	3.75	6.5	1	43
GN 2246-20-B5-6-NI	20	5-6	M 2.5	26	7.5	3.75	6.5	1	43
GN 2246-20-B5-8-NI	20	5-8	M 2.5	26	7.5	3.75	6.5	1	43
GN 2246-20-B6-6-NI	20	6-6	M 2.5	26	7.5	3.75	6.5	1	43
GN 2246-20-B6-8-NI	20	6-8	M 2.5	26	7.5	3.75	6.5	1	43
GN 2246-20-B8-8-NI	20	8-8	M 2.5	26	7.5	3.75	6.5	1	43
GN 2246-25-B6-6-NI	25	6-6	M 3	31	8.5	4.25	9	1.5	78
GN 2246-25-B6-8-NI	25	6-8	M 3	31	8.5	4.25	9	1.5	78
GN 2246-25-B6-10-NI	25	6-10	M 3	31	8.5	4.25	9	1.5	78
GN 2246-25-B8-8-NI	25	8-8	M 3	31	8.5	4.25	9	1.5	78
GN 2246-25-B8-10-NI	25	8-10	M 3	31	8.5	4.25	9	1.5	78
GN 2246-25-B10-10-NI	25	10-10	M 3	31	8.5	4.25	9	1.5	78
GN 2246-32-B10-10-NI	32	10-10	M 4	41	12	6	11	2.5	170
GN 2246-32-B10-12-NI	32	10-12	M 4	41	12	6	11	2.5	170
GN 2246-32-B12-12-NI	32	12-12	M 4	41	12	6	11	2.5	170

Couplings

Assembly instructions

SHAFT-HUB FASTENING

The right type of fastening must be selected to ensure simple and reliable mounting of the coupling hub on the shaft. The following shaft-hub fastening types are available:

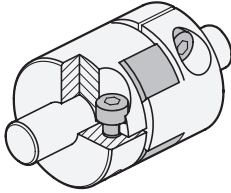
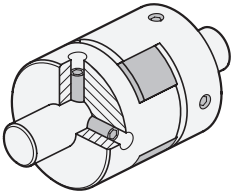
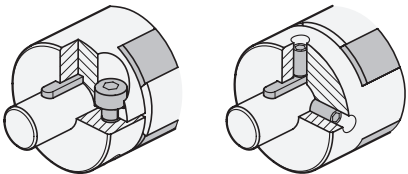
Clamping hub	
	<p>The fastening with clamping hubs is entirely non-positive by reducing the slit height using socket head screws.</p> <p>In this type, the coupling hub is fastened simply and securely with a high clamping force, without damaging the surface of the shafts.</p>
Grub screw	
	<p>When used for fastening, grub screws are inserted radially to create a positive and non-positive connection to the shaft surface.</p> <p>Alignment holes bored into the mounting diameter allow the coupling hub to be positioned precisely. At the same time, this prevents damage to the clamping point.</p>
Combination with keyway	
	<p>The combination of grub screw or clamping hub fastening with feather keys prevents slipping due to torque while ensuring precise angular positioning of the shafts.</p> <p>This type of fastening also provides for maximum torque transmission.</p>

SHAFT INSERTION DEPTH

For correct fastening of the coupling hubs, the shaft must be installed according to the recommended shaft insertion depth l_2 . The shaft insertion depth l_2 is specified in the standard sheet of the respective coupling.

If the insertion depth is too low, the shaft could slip out of the coupling, or the clamping hub could break. If the shaft is inserted too far, this can cause interference within the coupling, leading to damage.

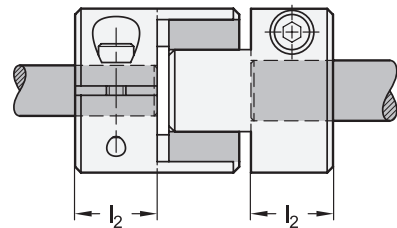

Couplings

Assembly instructions

ALIGNMENT ADJUSTMENT

Like all mechanical parts, shafts are subjected to manufacturing and assembly tolerances that generally cannot be entirely eliminated even with extensive technical measures. Couplings can compensate for the resulting misalignments while still ensuring transmission of the necessary torque.

However, if the misalignments exceed the permissible values, this results in vibrations that can quickly shorten the service life of the coupling. The actual shaft misalignment may, therefore, never be larger than the specified permissible values.

The permissible shaft misalignment values given in the standard sheet take into account only the lateral, angular or axial misalignment. In the event of combined misalignments consisting of two or more errors, each permissible value is reduced to half the value specified in the standard sheet.

In general, it is recommended to limit misalignments to no more than one third of the permissible value in the standard sheet. This is because shaft misalignment occurs not only during assembly. It often develops during operation as the result of vibrations, thermal expansion or bearing wear.

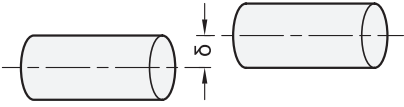
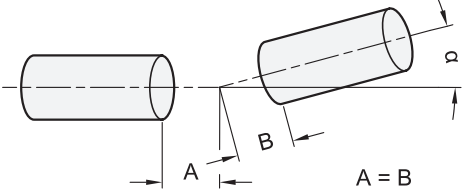
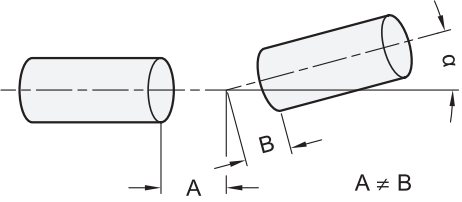
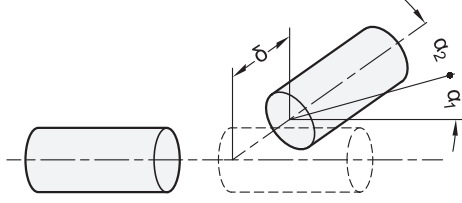
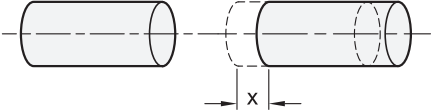
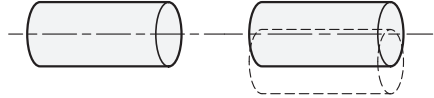
lateral	angular - symmetrical
	
angular - asymmetrical	lateral and angular
	
axial (axial motion)	runout
	

Couplings

Technical information / Definition of terms

RATED TORQUE

The torque that the coupling can transmit continuously. This value allows for load fluctuations during operation so that rated torque compensation is not required when selecting the couplings (excluding Oldham types). Select a coupling such that the load torque generated during continuous operation does not exceed the rated torque.

MAXIMUM TORQUE

The torque that the coupling can transmit momentarily.

ROTATIONAL SPEED

The maximum rotational speed of the coupling was calculated based on a peripheral speed of 33 m/s. Tests have confirmed that the coupling will not sustain damage at this speed.

MOMENT OF INERTIA (ROTATING MASS)

This indicates the coupling's resistance to rotation around its own axis. The lower the moment of inertia, the less load torque is required for starting and stopping the motor.

STATIC TORSIONAL STIFFNESS

The static torsional stiffness indicates the number of degrees by which a coupling twists depending on the introduced torque. Torsional stiffness is generally indicated as torque per unit of arc (Nm/rad). To simplify the design process, the torsional stiffness can also be converted to degrees per Nm.

Where:

$$2\pi \text{ rad} = 360^\circ \rightarrow 1 \text{ rad} = \frac{360^\circ}{2\pi} = \frac{180^\circ}{\pi} \approx 57.3^\circ$$

Example:

$$\text{Coupling with a torsional stiffness of } 500 \text{ Nm/rad} = \frac{500 \text{ Nm}}{57.3^\circ} \rightarrow \text{Reciprocal } \frac{57.3^\circ}{500 \text{ Nm}} \approx \frac{0.1146^\circ}{1 \text{ Nm}}$$

SLIP TORQUE

Slip torque refers to the torque at which the shaft begins to slip out of the clamping hub. This presumes that the clamping hub was installed at the specified screw tightening torque.

The slip torque values given in the table were derived from experimental testing. They are based on a shaft tolerance of h7, a shaft hardness of 34 to 40 HRC and the screw tightening torque for the clamping hub given in the table.

The load torque must be less than the slip torque for which the coupling is designed. It is also necessary to take into account that the slip torques given in the table are lower than the indicated maximum torque values. If no slip torque is specified, then the maximum torque can be achieved.

Because the slip torque changes due to operating conditions, the suitability of the selected coupling should be tested under real conditions.

GN 2240				
d ₁	d ₂ / d ₃	Slip torque in Nm ≈	Tightening torque of the screw in Nm ≈	
14	3	0.8	0.5	
14	4	1.4	0.5	
14	5	2.1	0.5	
14	6	1.3	0.25	
20	5	4.9	1	
20	6	6.4	1	
20	8	9.4	1	
30	8	9.3	3.5	
30	10	14.6	3.5	

Couplings

Technical information / Definition of terms

GN 2240			
d ₁	d ₂ / d ₃	Slip torque in Nm ≈	Tightening torque of the screw in Nm ≈
30	12	20	3.5
30	14	15.3	1.5
40	12	31.7	8
40	14	38.5	8
40	15	-	8
40	16	-	8
55	18	85	13
55	19	91.5	13
55	20	98	13
55	25	130	13

GN 2242			
d ₁	d ₂ / d ₃	Slip torque in Nm ≈	Tightening torque of the screw in Nm ≈
12	4	1.9	0.5
12	5	2.4	0.5
15	4	2.3	1
15	5	3.5	1
15	6	4.8	1
20	6	4.2	1.5
20	8	5.7	1.5
20	10	-	1.5
30	8	7.5	2.5
30	10	13.9	2.5
30	12	17.2	2.5
38	12	20.2	4
38	15	30	4
38	20	38.8	4

GN 2246			
d ₁	d ₂ / d ₃	Slip torque in Nm ≈	Tightening torque of the screw in Nm ≈
12	4	-	0.5
12	5	-	0.5
16	5	-	1
16	6	-	1
20	5	-	1
20	6	-	1
20	8	-	1
25	6	0.7	1.5
25	8	1.7	1.5
25	10	-	1.5
32	10	2.7	2.5
32	12	-	2.5

Couplings

Technical information / Definition of terms

TEMPERATURE CORRECTION FACTORS

If the ambient temperature is greater than 30 °C, the rated torque and the maximum torque must be adjusted using the temperature correction factors.

Ambient temperature	Temperature correction factor	
	for GN 2240 / GN 2241	for GN 2242 / GN 2243
-20 °C up to +30 °C	1	1
+30 °C up to +40 °C	0.8	0.8
+40 °C up to +60 °C	0.7	0.7
+60 °C up to +80 °C	-	0.55

STATIC TORSIONAL STIFFNESS AND TEMPERATURE

The diagrams show the change in static torsional stiffness within the permissible operating temperature range, under the assumption that the static torsional stiffness at 20 °C is 100 percent. The torsional stiffness of the couplings decreases with increasing temperature.

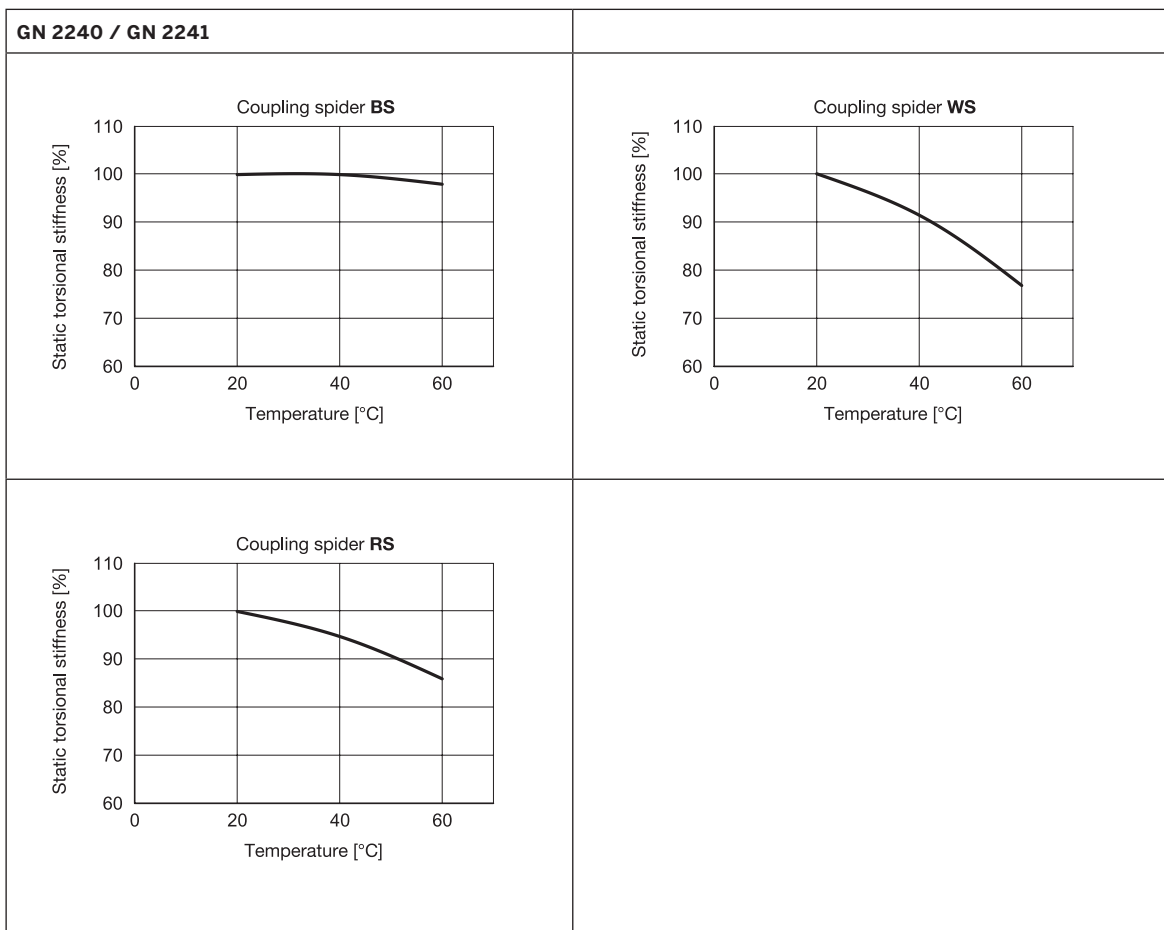

Couplings

Technical information / Definition of terms

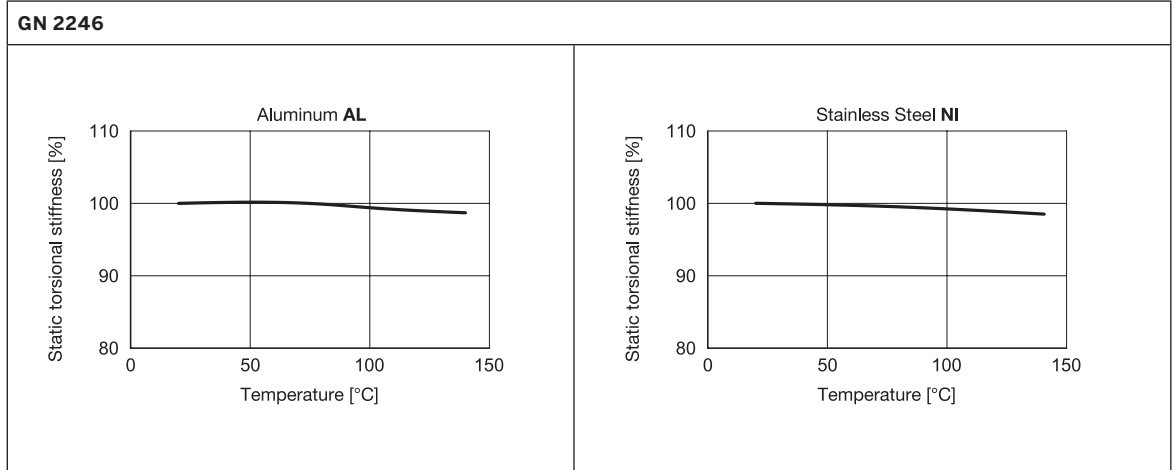
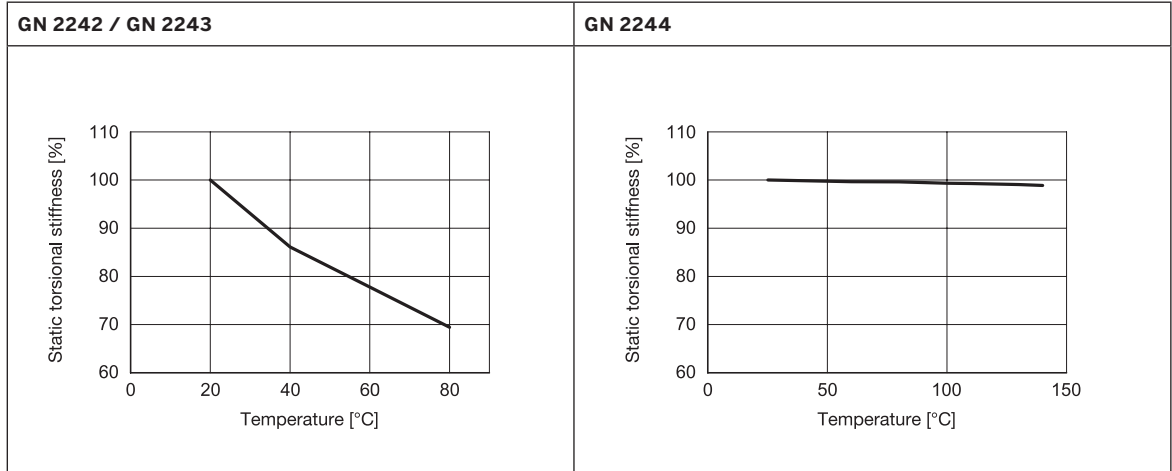

Couplings

Technical information / Definition of terms

RESTORING FORCE - ECCENTRICITY

When the shaft ends are installed in eccentric arrangements, the coupling constantly attempts to return to its neutral position. The resulting force is referred to as restoring force.

If the couplings are installed with the lowest possible eccentricity, the resulting restoring forces are lower. This also reduces the force acting on the shaft bearing.

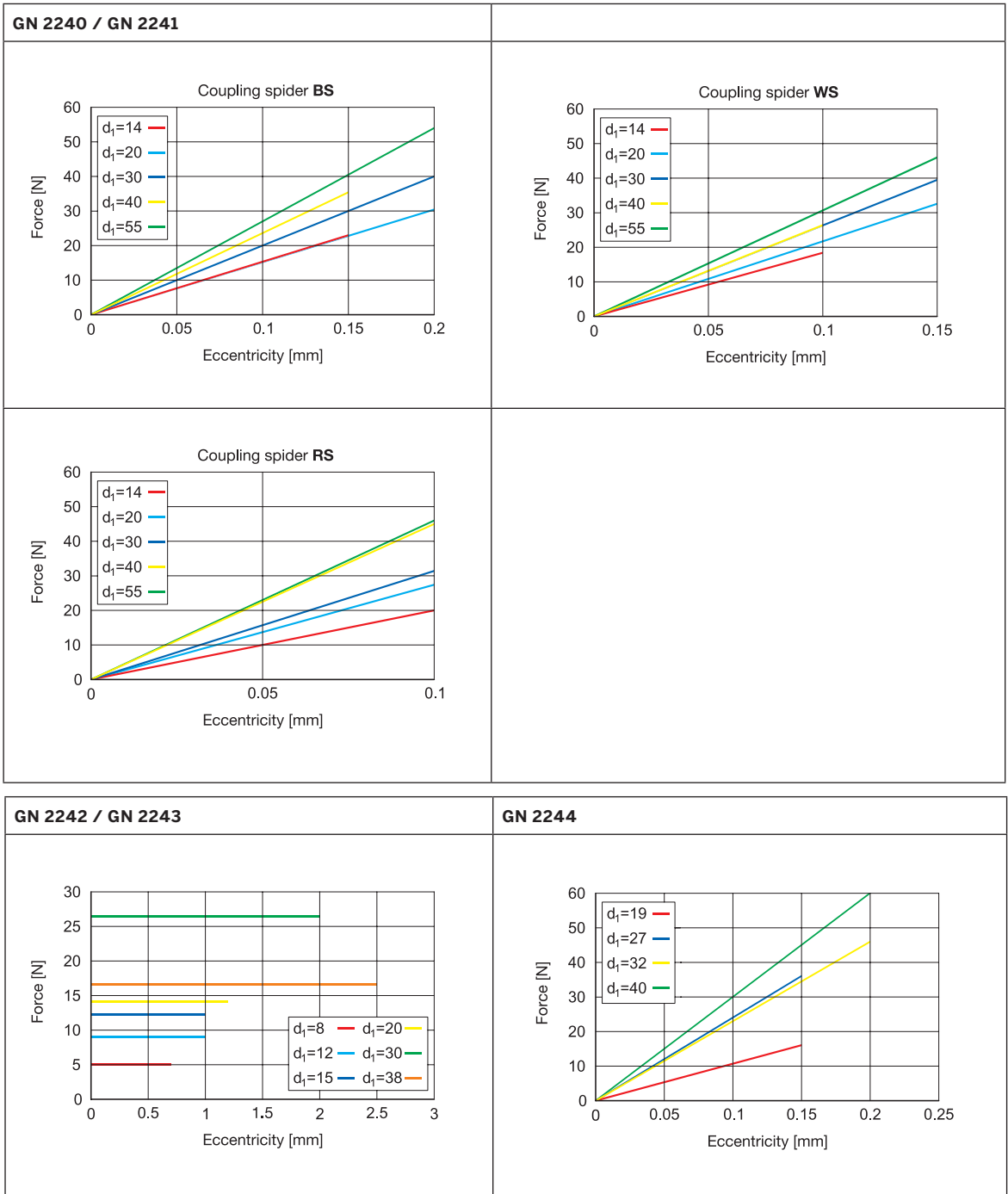

Couplings

Technical information / Definition of terms

GN 2246

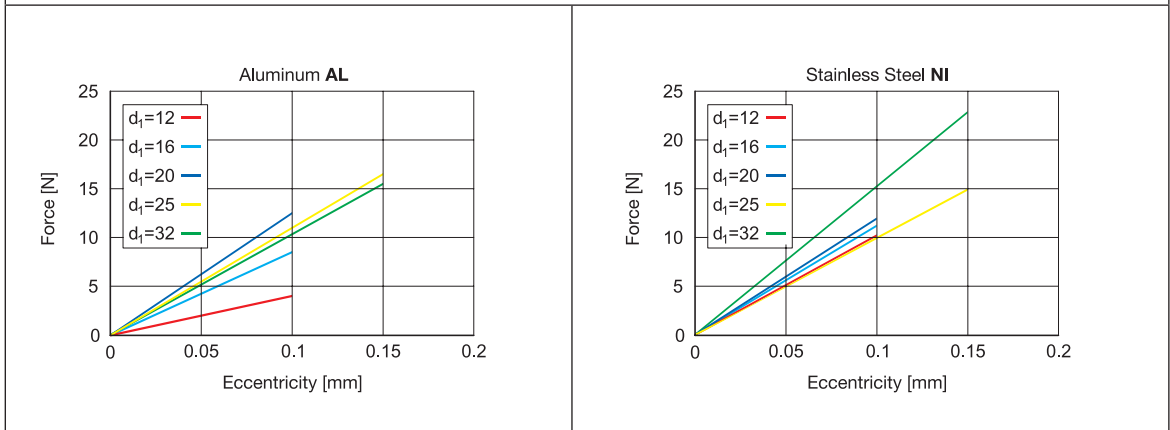

RESTORING FORCE - PRESSURE

If the coupling is under pressure, subject to compressive load in the axial direction, it will strive to return to its neutral position. The force that counteracts the compressive force is referred to as restoring force.

Lowering the compression acting on a coupling results in a lower restoring force and less force exerted axially. This must always be taken into account in dimensioning the coupling.

GN 2244

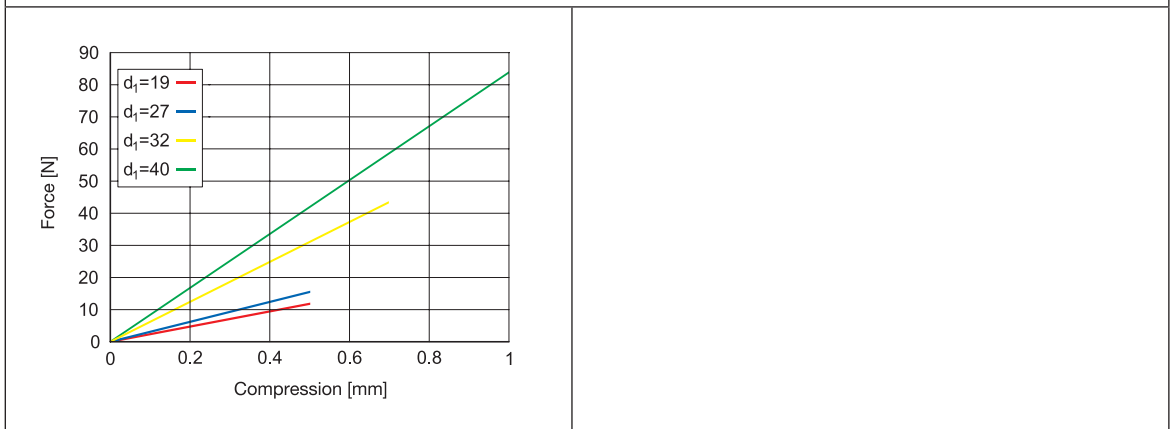

GN 2246

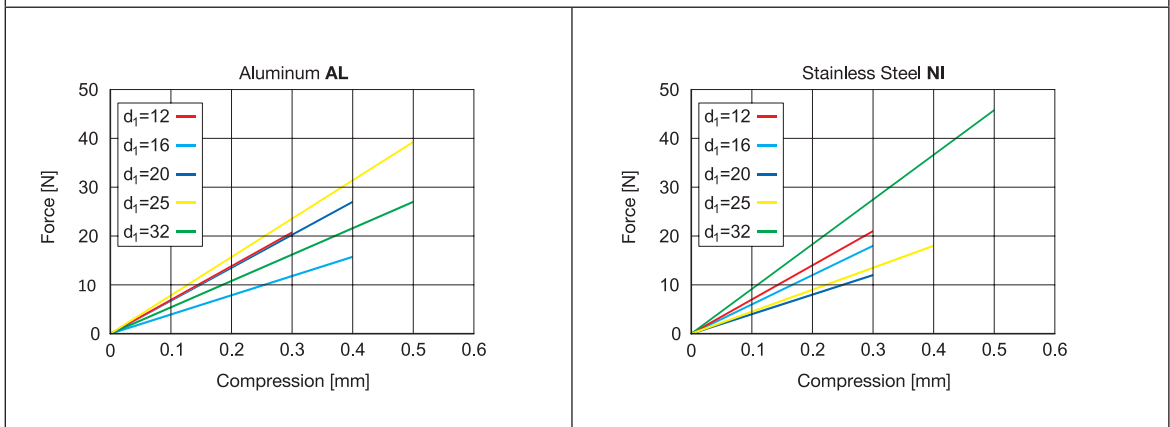

Couplings

Application examples

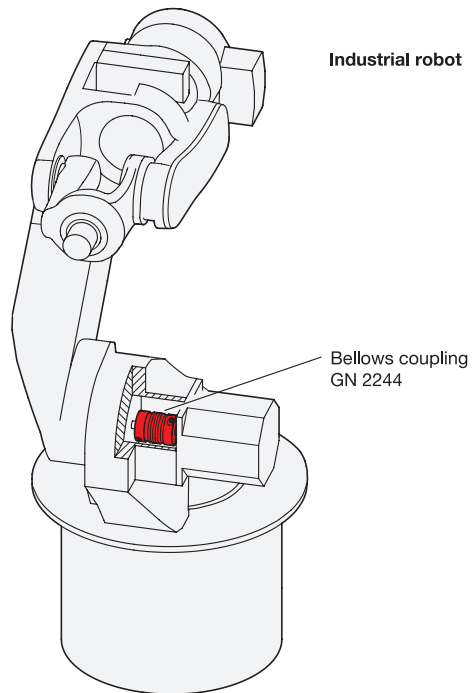
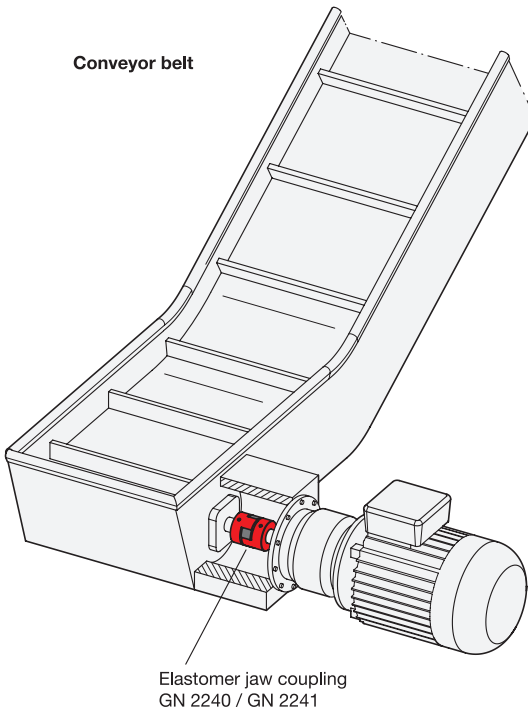

COPYRIGHT © 2021

Elesa S.p.A and OTTO GANTER GmbH & Co. KG

All rights reserved.

No part of this catalogue can be reproduced in whole

or in part without prior written permission from

Elesa S.p.A or OTTO GANTER GmbH & Co. KG



Find out more on [elesa-ganter.com](https://www.elesa-ganter.com)

ELESA S.p.A.
Via Pompei 29
20900 Monza (MB)
Italy
+39 039 28 111
info@elesa.com
elesa.com

OTTO GANTER GmbH & Co.KG
Triberger Straße 3
78120 Furtwangen
Germany
+49 7723 65 07 0
info@ganternorm.com
ganternorm.com



**DESIGNED
FOR ENGINEERING**